



HDMI to CAT5e Daisy Chain HD Extender Kit with RS-232 & IR Installation Guide

Introduction

The *HDMI to CAT5e Daisy Chain HD Extender Kit with RS-232 & IR* extends HDMI signal over one Cat5/6 cable up to 330ft and is cascade connection supported.

Features and Benefits





- Extend HDMI signals up to 100m over Cat5e/6 cabling
- Cascade receivers up to 10 layers
- Supports video high resolution Full HD 1080p, 1920 x 1080
- High Definition Audio (HD) Surround Sound
- RS-232 (Serial) and IR (Infrared Remote) enabled
- Metal housing with mounting mechanism

Package Contents

CE-H22611-S1

Transmitter unit (Tx)	Receiver unit (Rx)	Power adapter 5V / 2A (2)
3.5mm to RS-232 cable (2)	IR extension cable (2)	Installation guide

CE-H22711-S1

Repeater unit (Rx)	Power adapter 5V/2A	3.5mm to RS-232 cable
		
IR extension cable	Installation guide	
		

Layout

Transmitter Unit (Tx)

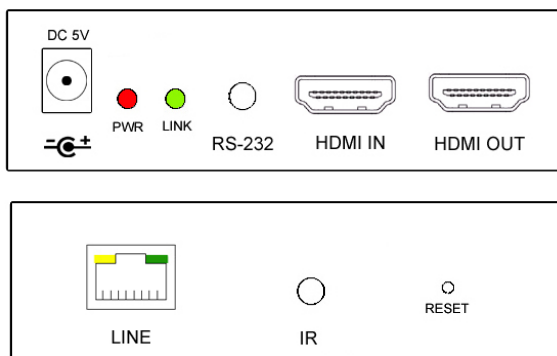

Figure 1: Transmitter side panel

- **DC 5V:** DC 5V power jack. Plug the included power adapter here
- **PWR:** LED indicator for power status. On/Off when the *Transmitter* is powered on/off
- **LINK:** LED indicator for link status. On when the connection of *Transmitter* and *Receiver* is established and detected

- **RS-232:** RS-232 control port. Plug the included 3.5mm to RS-232 cable then an RS-232 cable here, if needed
- **HDMI IN:** HDMI signal input port. Connect this port to your HDMI source device by using an HDMI cable (not included)
- **HDMI OUT:** HDMI signal output port. Connect this port to a local HDMI display by using an HDMI cable (not included)
- **LINE :** Signal output port, connected with *Receiver's* LINE port by using a CAT X cable (not included)
- **IR:** Connect to the included IR blaster cable
- **RESET:** Use the fine end of any object to press and hold the bottom to return to default settings

Receiver / Repeater Unit (Rx)

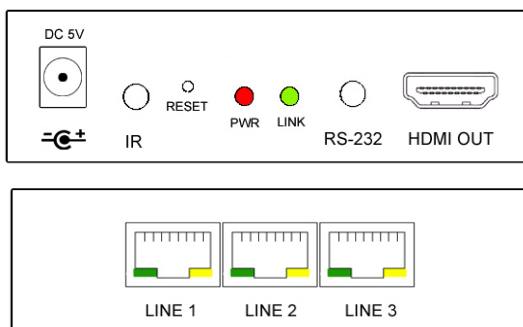

Figure 2: Receiver/Repeater side panel

- **DC 5V:** DC 5V power jack. Plug the included power adapter here
- **IR:** Connect to the included IR receiver cable
- **RESET:** Use the fine end of any object to press and hold the bottom to return to default settings

- **PWR:** LED indicator for power status. On/Off when the *Receiver/Repeater* is powered on/off
- **LINK:** LED indicator for link status. On when the connection of *Transmitter* and *Receiver* is established and detected
- **RS-232:** RS-232 control port. Plug the included 3.5mm to RS-232 cable then an RS-232 cable here, if needed
- **HDMI OUT:** HDMI signal output port. Connect this port to the remote HDMI display by using an HDMI cable (not included)
- **LINE 1-3:** Signal input port, connected with *Transmitter's* **LINE** port by using a CAT X cable (not included).

Either one port is connected to the *Transmitter* unit, the other two ports could be connected to other *Receivers/Repeaters* for further signal extension or expansion. See the Function Diagram section on page 7-10 for more details

IR Extension Cables



Figure 3a: IR blaster cable



Figure 3b: IR receiver cable

To control the source device from *Receiver's* end:

1. Plug the IR blaster cable to the *Transmitter's* **IR** connector, then plug the IR receiver cable to the *Receiver's* **IR** connector.

2. Point your source device's remote control to the IR receiver's eye, the command will be sent to *Transmitter* end, and the connected source device will enforce the command accordingly.

Hardware Installation

1. Power off all devices, including the source device and display.
2. Connect your HDMI source (such as a PC or NB) to the *Transmitter's* **HDMI IN** connector by using an HDMI cable.
3. Connect the local HDMI display to *Transmitter's* **HDMI OUT**.

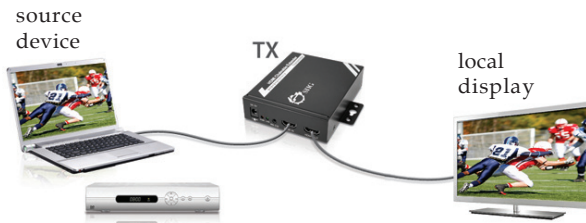

Figure 4

4. Connect a remote HDMI display (such as a LCD TV) to the *Receiver's* **HDMI OUT** connector.



Figure 5

5. Connect the **IR blaster cable** and **IR receiver cable** to the *Transmitter* and *Receiver's* **IR** ports respectively. Skip this step if IR control is not needed.

6. Connect the two 3.5mm to RS-232 cables to the *Transmitter* and *Receiver's* **RS-232** ports respectively. Skip this step if RS-232 control is not needed.
7. Connect your CAT5/6 cable between the *Transmitter's* and *Receiver's* **LINE** port. Make sure the CAT5/6 LAN cable is securely connected.

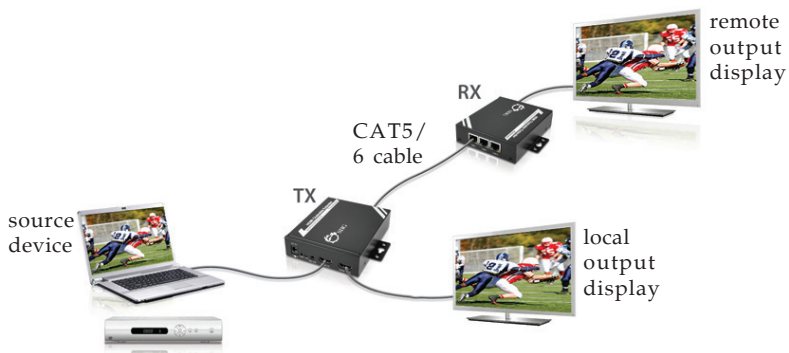

Figure 6

8. Each *Receiver/Repeater* can cascade-daisy chain to 2 or more *Receivers/Repeaters* for extending or expanding. Skip this step if extending is not needed.
9. Plug the included power adapters into the **DC 5V** power jack of the *Transmitter* and *Receiver* separately. Power on the connected display(s), the *Extender kit* is ready for use.

Function Diagram

Basic Connection

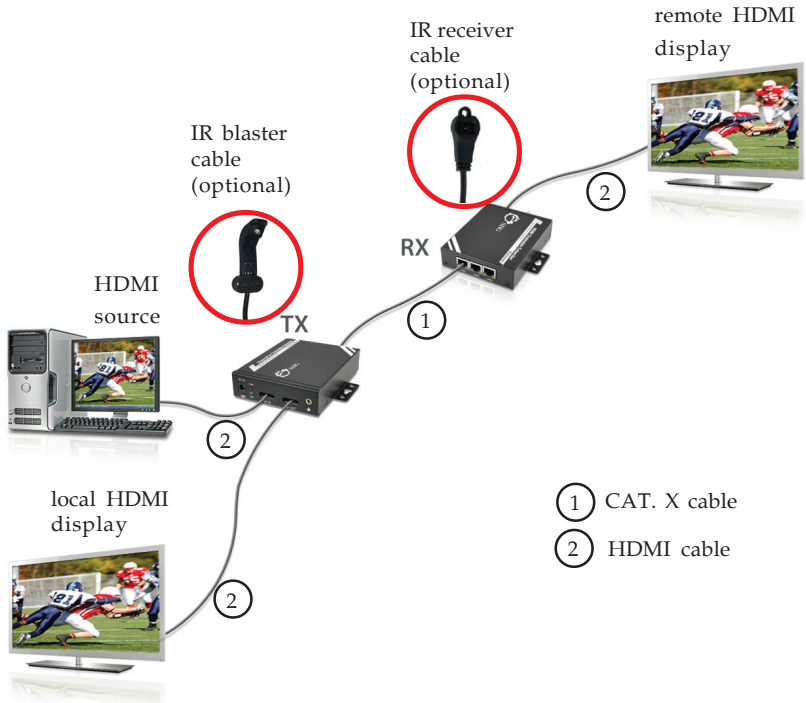

Figure 7

- The extension distance through CAT. X cable is up to 100 meters for one layer

Advanced Connections

Daisy Chain Connection

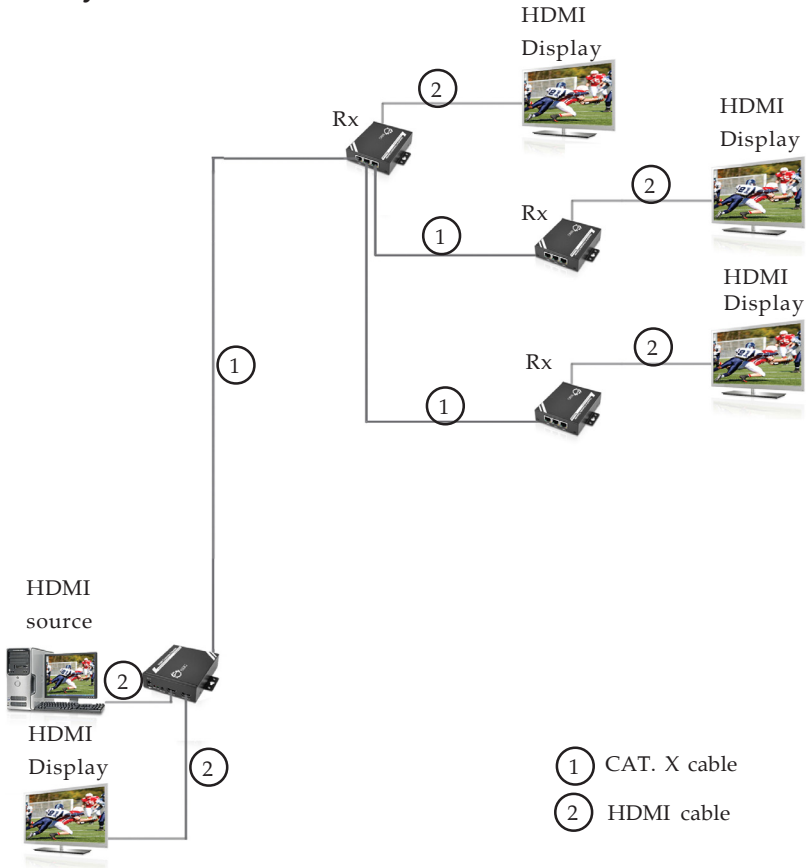

Figure 8

- The extension distance through CAT. X cable is up to 100 meters for one layer

Cascade Connection

- ① CAT. X cable
- ② HDMI cable

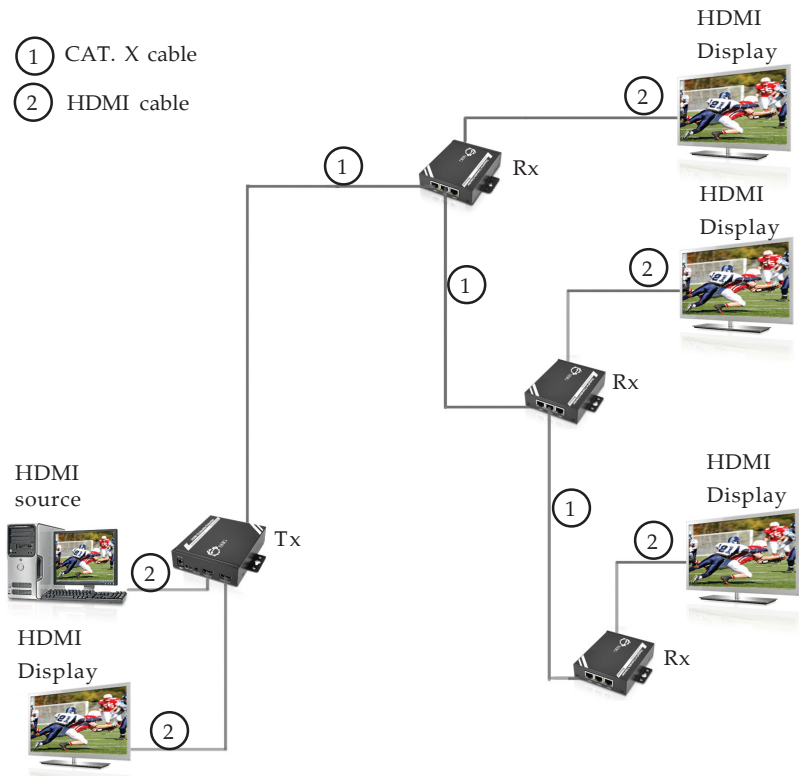

Figure 9

- Cascade receivers up to 10 layers; extension distance through CAT. X cable up to 100 meters for one layer

Gigabit Ethernet Switch Connection

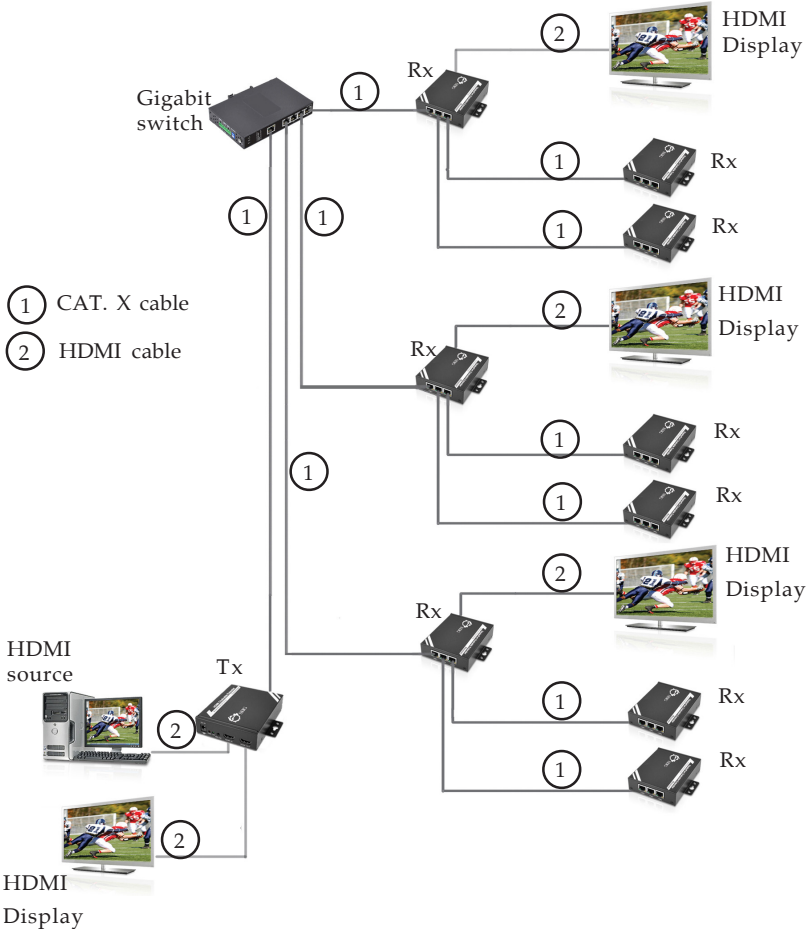

Figure 10: Used with Gigabit Ethernet switch

- Connect with the Gigabit Ethernet switch especially when your Tx or Rx unit has only one signal input/output port
- The extension distance through CAT. X cable is up to 100 meters for one layer

Technical Support and Warranty

QUESTIONS? SIIG' s **Online Support** has answers! Simply visit our web site at www.siig.com and click **Support**. Our online support database is updated daily with new drivers and solutions. Answers to your questions could be just a few clicks away. You can also submit questions online and a technical support analyst will promptly respond.

SIIG offers a 2-year manufacturer warranty with this product. This warranty covers the original purchaser and guarantees the product to be free of any defects in materials or workmanship for two (2) years from the date of purchase of the product.

SIIG will, at our discretion, repair or replace (with an identical product or product having similar features and functionality) the product if defective in materials or workmanship. This warranty gives you specific legal rights, and you may also have other rights which vary from state to state. Please see our web site for more warranty details.

If you encounter any problems with this product, please follow the procedures below.

A) If it is within the store's return policy period, please return the product to the store where you purchased it.

B) If your purchase has passed the store's return policy period, please follow these steps to have the product repaired or replaced.

Step 1: Submit your RMA request. Go to www.siig.com, click **Support**, then **Request A Product Replacement** to submit a request to [SIIG RMA](#) or fax a request to 510-657-5962. Your RMA request will be processed, if the product is determined to be defective, an RMA number will be issued.

Step 2: After obtaining an RMA number, ship the product.

- Properly pack the product for shipping. All software, cable(s) and any other accessories that came with the original package must be included.
- Clearly write your RMA number on the top of the returned package. SIIG will refuse to accept any shipping package, and will not be responsible for a product returned without an RMA number posted on the outside of the shipping carton.
- You are responsible for the cost of shipping to SIIG. Ship the product to the following address:

SIIG, Inc.
6078 Stewart Avenue
Fremont, CA 94538-3152, USA
RMA #: _____

- SIIG will ship the repaired or replaced product via Ground in the U.S. and International Economy outside of the U.S. at no cost to the customer.

About SIIG, Inc.

Founded in 1985, SIIG, Inc. is a leading manufacturer of IT connectivity solutions (including Serial ATA and Ultra ATA Controllers, FireWire, USB, and legacy I/O adapters) that bridge the connection between Desktop/ Notebook systems and external peripherals. SIIG continues to grow by adding A/V and Digital Signage connectivity solutions to our extensive portfolio. All centered around the distribution and switching of A/V signals over CAT5/6, these products include matrix switches, distribution amplifiers, extenders, converters, splitters, cabling, and more.

SIIG is the premier one-stop source of upgrades and is committed to providing high quality products while keeping economical and competitive prices. High-quality control standards are evident by one of the lowest defective return rates in the industry. Our products offer comprehensive user manuals, user-friendly features, and most products are backed by a lifetime warranty.

SIIG products can be found in many computer retail stores, mail order catalogs, and e-commerce sites in the Americas, as well as through major distributors, system integrators, and VARs.

PRODUCT NAME

HDMI to CAT5e Daisy Chain HD Extender Kit
with RS-232 & IR

FCC RULES: TESTED TO COMPLY WITH FCC PART 15, CLASS
B OPERATING ENVIRONMENT: FOR HOME OR OFFICE USE

FCC COMPLIANCE STATEMENT:

This device complies with part 15 of the FCC Rules. Operation is subject to the following two conditions: (1) This device may not cause harmful interference, and (2) this device must accept any interference received, including interference that may cause undesired operation.

THE PARTY RESPONSIBLE FOR PRODUCT COMPLIANCE

SIIG, Inc.
6078 Stewart Avenue
Fremont, CA 94538-3152, USA
Phone: 510-657-8688

HDMI to CAT5e Daisy Chain HD Extender Kit with RS-232 & IR is a trademark of SIIG, Inc. SIIG and the SIIG logo are registered trademarks of SIIG, Inc. Microsoft and Windows are registered trademarks of Microsoft Corporation. All other names used in this publication are for identification only and may be trademarks of their respective owners.