

Easy Access Full-Motion Monitor Desk Mount - 13" to 27"

Installation Instructions



Unpacking

- Carefully remove the contents and lay them out on cardboard or other protective surface
- Check package contents against the parts list to ensure that all components are received undamaged. Do not use damaged or defective parts
- Carefully read all instructions before attempting installation

Safety Information

- Use proper safety equipment during installation
- If you don't understand the installation instructions, please consult an installation specialist
- This mount contains small parts which can act as a choking hazard if swallowed
- Do not use this product for any purpose or in any configuration not explicitly specified in these instructions

Tools Required

- Phillips and flat head screwdriver
- 3/8" drill bit and Electric drill (for grommet installation)
- Ratchet set or adjustable wrench

Parts List

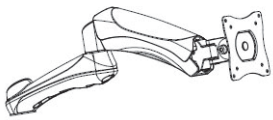

(1x) Extension Arm (A)

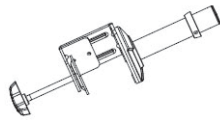

(1x) Tube Support with C-Clamp (B)



(1x) Grommet Plate (C)



(5x) Rubber Pad (D)



(1x) Grommet Clamp (E)



(1x) 3mm Allen Key (F)



(1x) 6mm Allen Key (G)



(4x) M4x12 Bolt (M-A)



(4x) M5x12 Bolt (M-B)



(4x) Washer (M-C)

Installation

Caution: This monitor desk mount must be securely attached to the horizontal desktop. If the mount is not properly installed it may fall, resulting in bodily injury and/or property damage.

1A) C Clamp Installation

1. Place the Rubber Pads (D) onto the upper desk clamp, see Figure 1.
2. Position the Tube Support to the desktop. Loosen the clamp screw according to the thickness of the desktop. Tighten the C-Clamp to the desktop by turning the clamp screw counter clockwise, see Figure 2.
3. Install the Position Ring at the desired height and tighten the screw using 3mm Allen Key (F) or screwdriver, see Figure 2a.

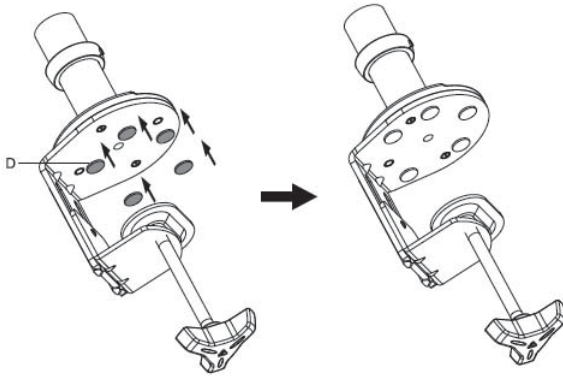

Figure 1

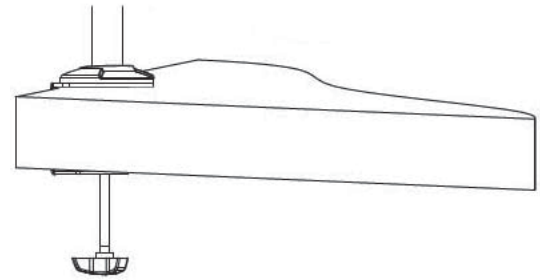

Figure 2

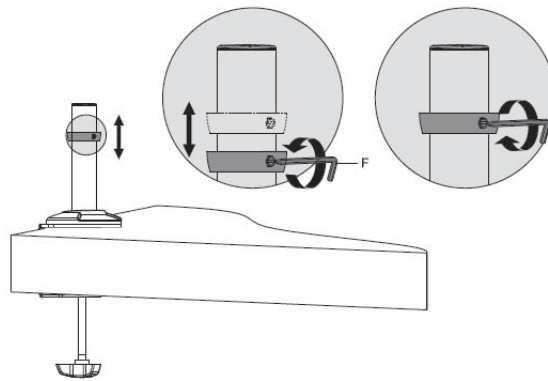

Figure 2a

1B) Grommet Hole Installation

This installation requires you to either drill a 3/8" (10mm) diameter hole through the desktop or use an existing grommet hole (2.25" diameter max). **Note:** If the existing grommet hole comes with a plastic protector, remove it to ensure a flat surface before installing the Tube Support.

1. Lift up the plastic cover and use a 3mm Allen Key (F) to remove the Hex Nut from the C-Clamp, see Figure 3.
2. Rotate the Steel Tube counter clockwise to separate it from the C-Clamp. Remove the support plate from the clamp screw using a phillips screwdriver, see Figure 4.
3. Connect the Steel Tube into the Grommet Plate and turn clockwise to tighten it. Use the 3mm Allen Key (F) to tighten the Hex Nut, see Figure 5.
4. Place Rubber Pads (D) onto the bottom of the Grommet Plate (C), see Figure 6.
5. Insert the clamp screw into the Grommet Clamp (E). Position the Tube Support on the mounting surface, then secure it using the Grommet Clamp (E) and clamp screw, see Figure 7.
Warning: Carefully screw the clamp screw into the Grommet Plate to prevent cross-threading and damage to the clamp screw.

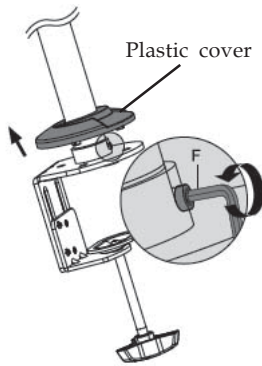

Figure 3

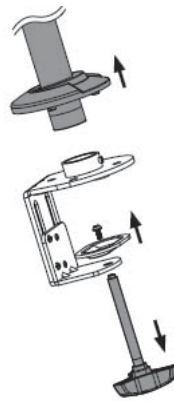

Figure 4

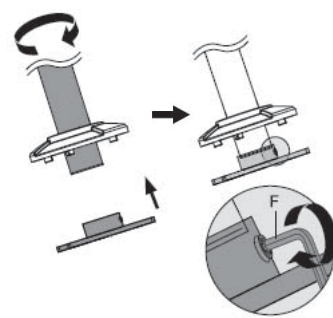

Figure 5

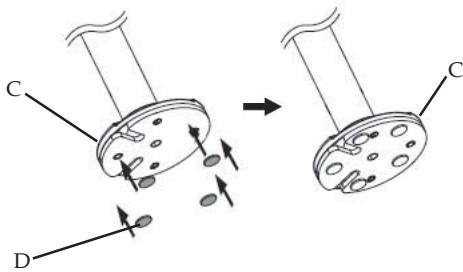

Figure 6

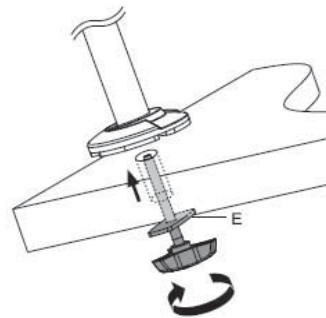

Figure 7

2. Mount the monitor to the Extension Arm Vesa plate, using Washer (M-C) and either M4x12 bolt (M-A) or M5x12 bolt (M-B) and tighten it using a phillips screwdriver, see Figure 8.

Note: When assembling/disassembling the monitor, the spring arm rebound tension may cause serious personal injury if not handled correctly.

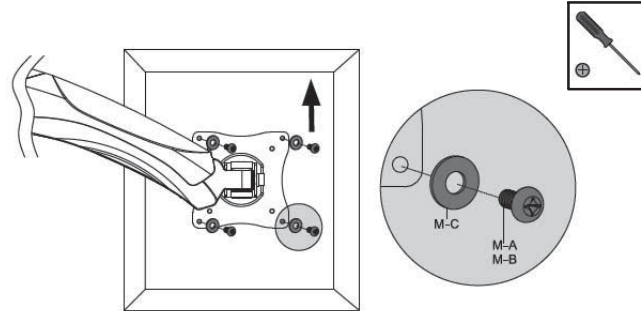

Figure 8

3. Slide the Extension Arm over the Tube Support until it rests on the Position Ring, then tighten the Hex Nut finger tight using a 3mm Allen Key (F), see Figure 9.

Caution: DO NOT over tighten the Hex Nut. The Extension Arm is intended to rotate and is not meant to be attached in a fixed position. Over tightening the Hex Nut may result in damage to the Extension Arm and Tube Support.

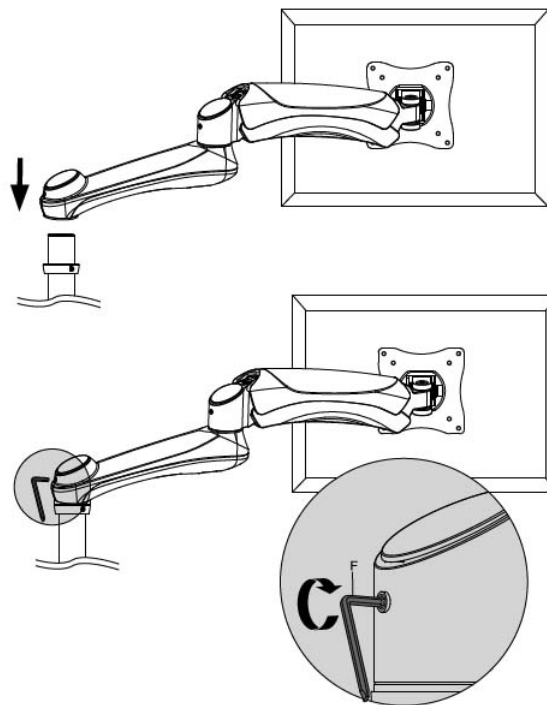
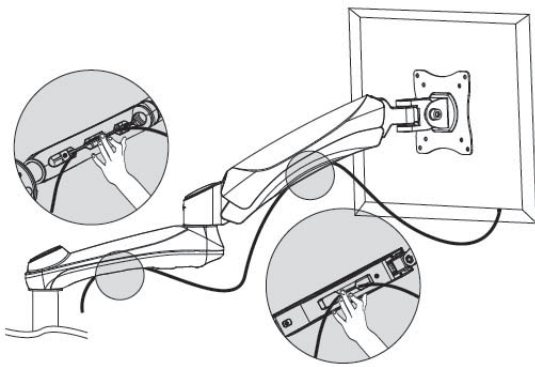
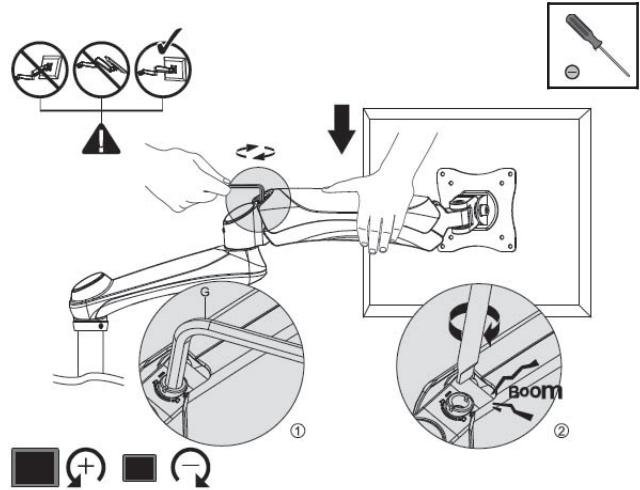

Figure 9

4. Check the tightness, arrange the cables, and make any final adjustments.



Arrange the cables into the cable covers



Adjust tightness of the Extension Arm and Spring Arm pivot joint using a 6mm Allen Key (G)

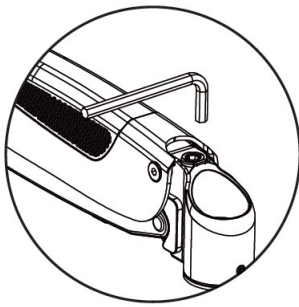

NOTE: turn clockwise to reduce tension for lighter monitors and counter-clockwise to increase tension for heavier monitors.

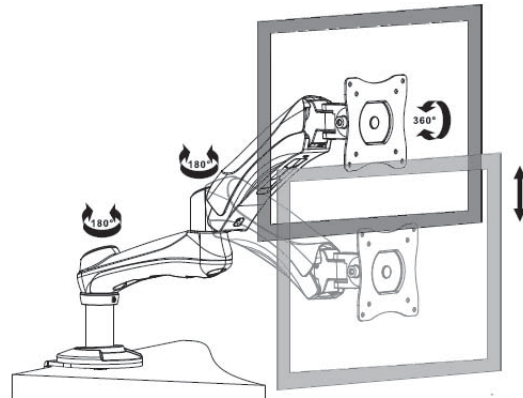

Adjust the Tension of the Gas Shock using a 6mm Allen Key (G)

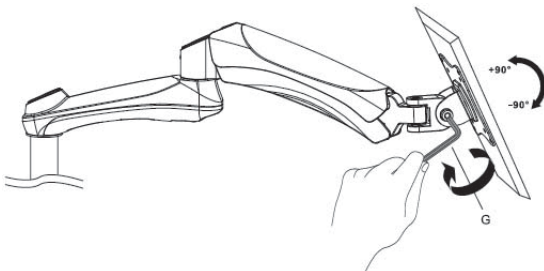

Adjust Tightness of Monitor Tilt and Swivel using 6mm Allen Key (G)

Maintenance

Check the mounting screws every two months for tightness.

Blank Page

Technical Support and Warranty

QUESTIONS? SIIG's **Online Support** has answers! Simply visit our web site at www.siig.com and click **Support**. Our online support database is updated daily with new drivers and solutions. Answers to your questions could be just a few clicks away. You can also submit questions online and a technical support analyst will promptly respond.

SIIG offers a 3-year manufacturer warranty with this product. This warranty covers the original purchaser and guarantees the product to be free of any defects in materials or workmanship for three (3) years from the date of purchase of the product.

SIIG will, at our discretion, repair or replace (with an identical product or product having similar features and functionality) the product if defective in materials or workmanship. This warranty gives you specific legal rights, and you may also have other rights which vary from state to state. Please see our web site for more warranty details.

If you encounter any problems with this product, please follow the procedures below.

A) If it is within the store's return policy period, please return the product to the store where you purchased from.

B) If your purchase has passed the store's return policy period, please follow the steps below to have the product repaired or replaced.

Step 1: Submit your RMA request.

Go to www.siig.com, click **Support**, then **Request A Product Replacement** to submit a request to [SIIG RMA](#) or fax a request to 510-657-5962. Your RMA request will be processed, if the product is determined to be defective, an RMA number will be issued.

Step 2: After obtaining an RMA number, ship the product.

- Properly pack the product for shipping. All accessories that came with the original package must be included.
- Clearly write your RMA number on the top of the returned package. SIIG will refuse to accept any shipping package, and will not be responsible for a product returned without an RMA number posted on the outside of the shipping carton.
- You are responsible for the cost of shipping to SIIG. Ship the product to the following address:
SIIG, Inc.
6078 Stewart Avenue
Fremont, CA 94538-3152, USA
RMA #: _____
- SIIG will ship the repaired or replaced product via Ground in the U.S. and International Economy outside of the U.S. at no cost to the customer.

About SIIG, Inc.

Founded in 1985, SIIG, Inc. is a leading manufacturer of IT connectivity solutions (including Serial ATA and Ultra ATA Controllers, FireWire, USB, and legacy I/O adapters) that bridge the connection between Desktop/Notebook systems and external peripherals. SIIG continues to grow by adding A/V and Digital Signage connectivity solutions to our extensive portfolio. All centered around the distribution and switching of A/V signals over CAT5/6, these products include matrix switches, distribution amplifiers, extenders, converters, splitters, cabling, and more.

SIIG is the premier one-stop source of upgrades and is committed to providing high quality products while keeping economical and competitive prices. High-quality control standards are evident by one of the lowest defective return rates in the industry. Our products offer comprehensive user manuals, user-friendly features, and most products are backed by a lifetime warranty.

SIIG products can be found in many computer retail stores, mail order catalogs, and e-commerce sites in the Americas, as well as through major distributors, system integrators, and VARs.

PRODUCT NAME

Easy Access Full-Motion Monitor Desk Mount - 13" to 27"

Easy Access Full-Motion Monitor Desk Mount - 13" to 27" is a trademark of SIIG, Inc. SIIG and the SIIG logo are registered trademarks of SIIG, Inc. All other names used in this publication are for identification only and may be trademarks of their respective owners.