

Articulated Freestanding Dual Monitor Desk Stand - 13" to 27"

Installation Instructions

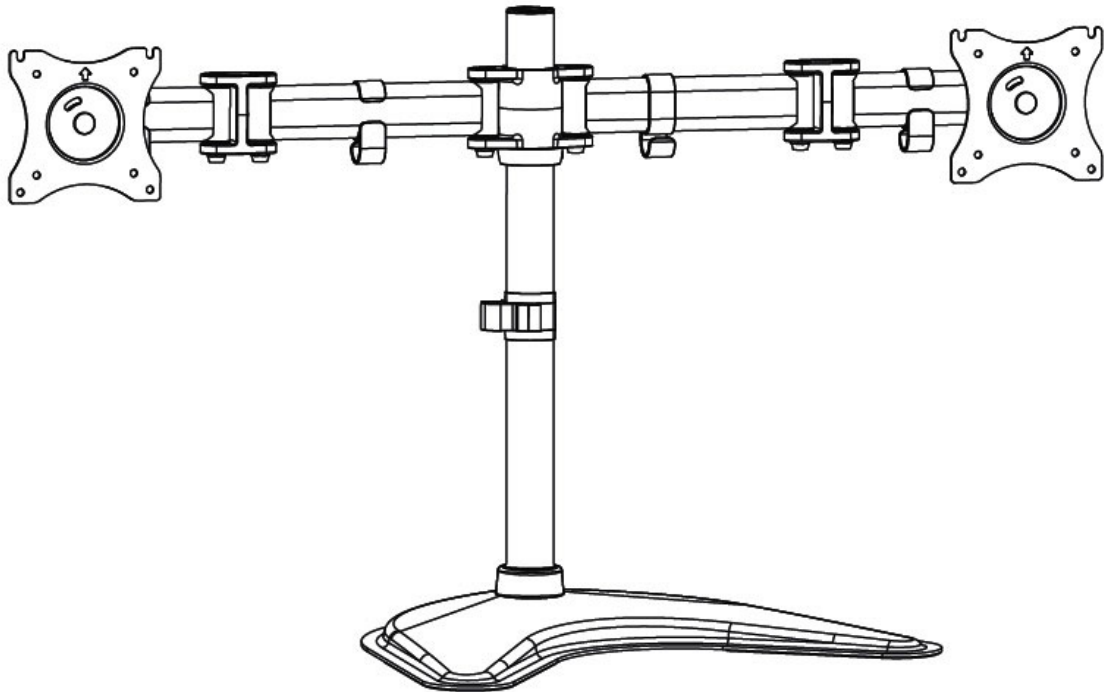

Unpacking

- Carefully remove the contents and lay them out on cardboard or other protective surface
- Check package contents against the parts list to ensure that all components were received undamaged. Do not use damaged or defective parts
- Carefully read all instructions before attempting installation

Safety Information

- Use proper safety equipment during installation
- If you don't understand the installation instructions, please consult an installation specialist
- This mount contains small parts which can act as a choking hazard if swallowed
- Do not use this product for any purpose or in any configuration not explicitly specified in these instructions

Tools Required

- Flat head screwdriver
- Phillips screwdriver

Parts List



A - (1x) Weighted Base



B - (1x) Tube Support

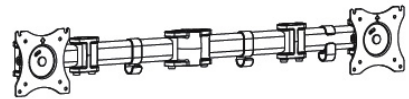

C - (1x) Arm Assembly with Vesa Plate



D - (1x) Cable Management Clip



E - (1x) Plastic Cover



F - (1x) 3mm Allen Key



G - (1x) 5mm Allen Key



H - (1x) 6mm Allen Key



M-A - (8x) M4x12 Bolt

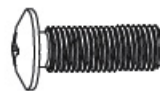

M-B - (8x) M5x12 Bolt



M-C - (8x) Washer

Installation

Step 1 - Mounting the Tube Support to the Weighted Base

Slide the Cable Management Clip (D) and Plastic Cover (E) onto the tube support, then mount the Tube Support (B) to the Weighted Base (A) by turning it clockwise until hand tight. Next, use the 3mm Allen Key (F) to tighten the set screws to secure the tube support, see Figure 1. Continue to Step 2.

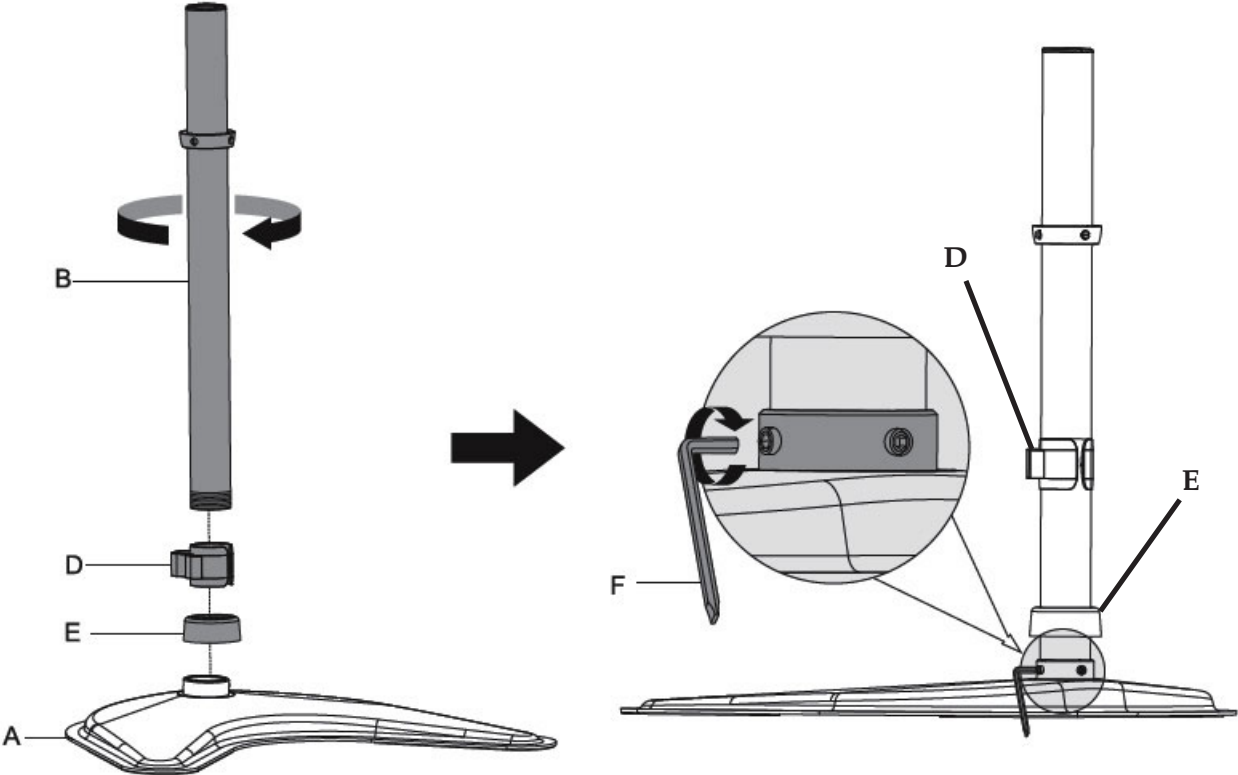

Figure 1

Step 2 - Install the Arm Assembly with VESA Plate onto the Tube Support

1. Install the **Position Ring** at the desired height then secure it using the included **3mm Allen Key (F)** or a flat head screwdriver, as shown in **Figure 2A**.

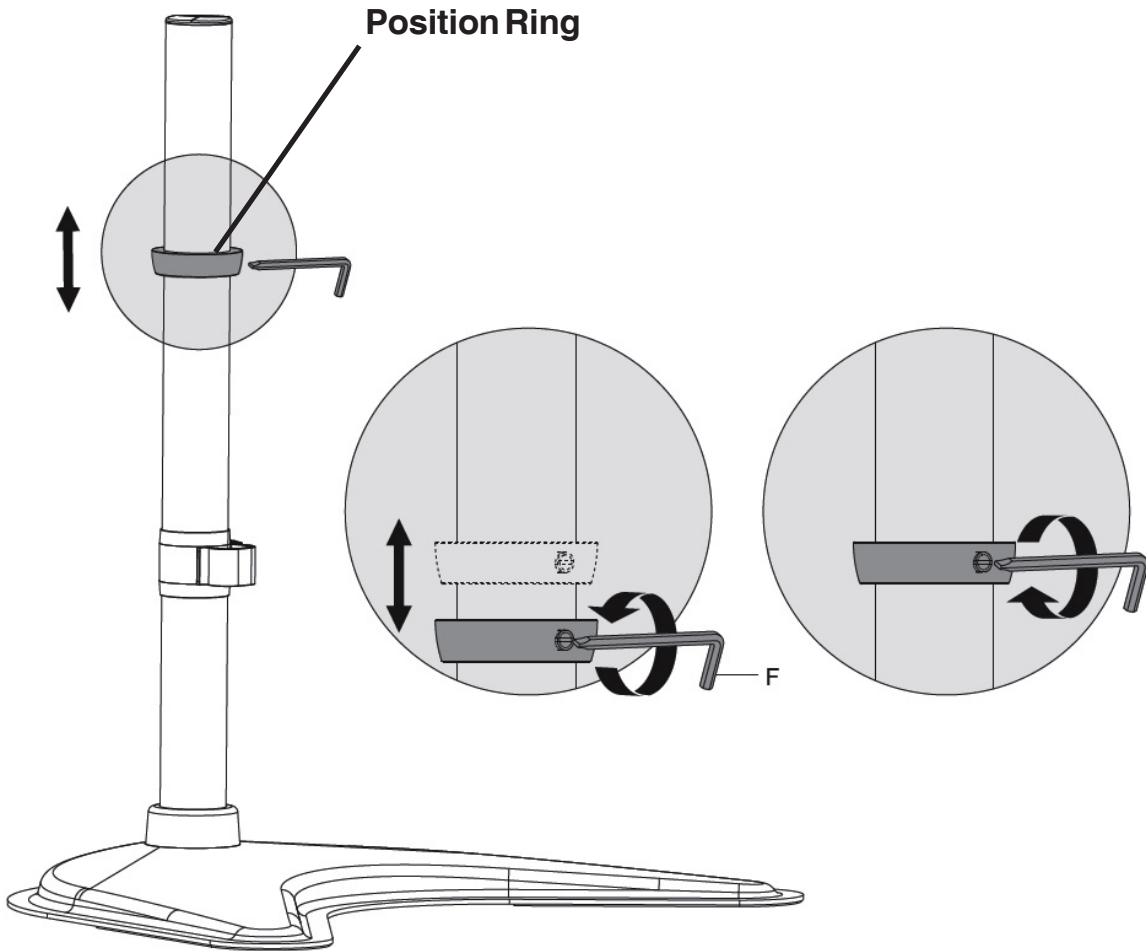

Figure 2A

2. Mount the **Arm Assembly with VESA Plate (C)** to the tube support so it rests on top of the position ring, secure it by tightening the clamp bolt using the included **5mm Allen Key (G)** as shown in **Figure 2B**. Do not overtighten the clamp bolt, doing so may damage the clamp or tube support. Continue to **Step 3**.

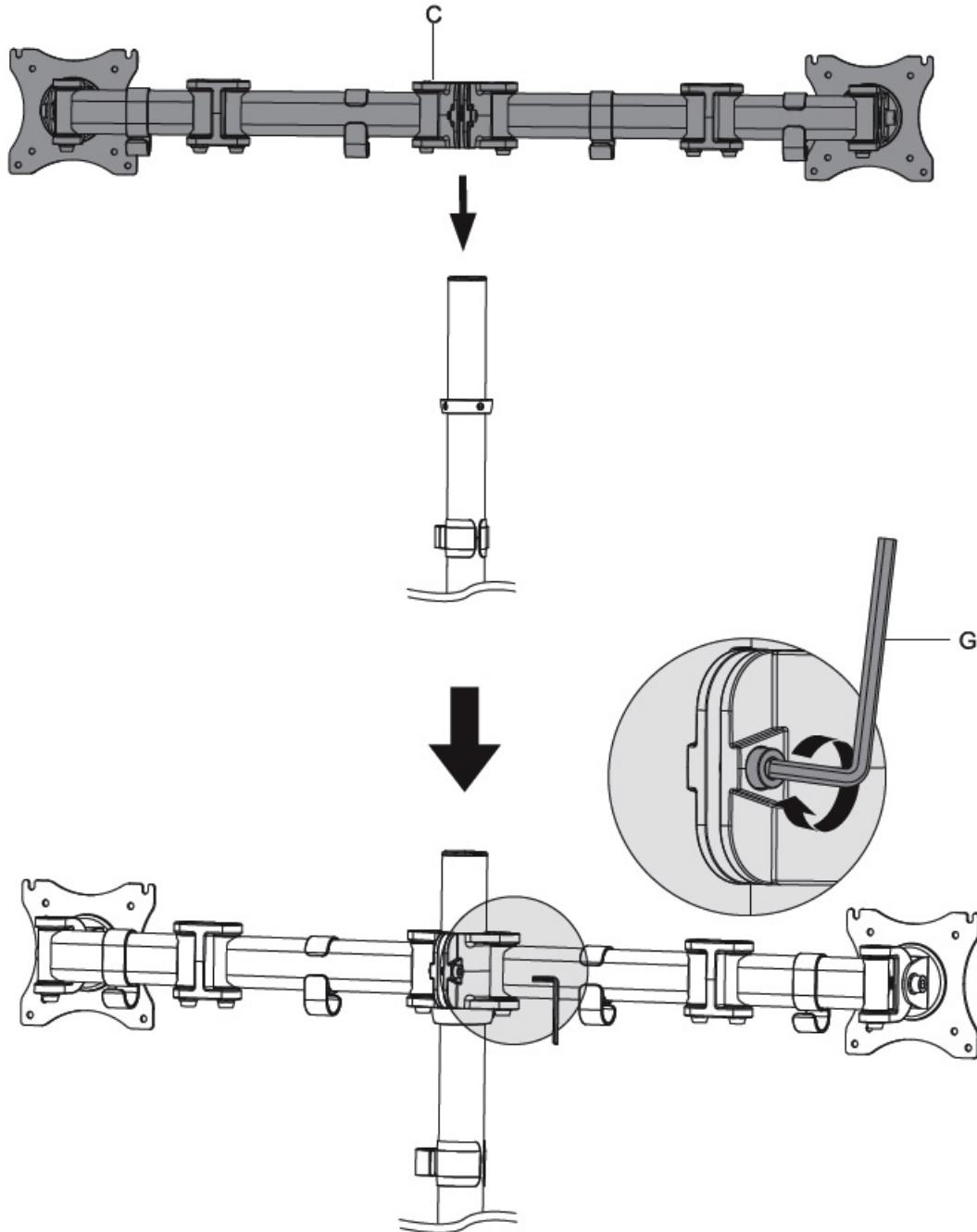

Figure 2B

Step 3 - Mounting the Displays to the VESA plate.

We suggest you have a helper hold the desk stand upright while attaching your displays to prevent damage to the displays or desk stand and to ensure your personal safety.

1. Rotate the VESA plate so that the mounting arrow is pointing upwards. In this orientation the slotted mounting holes will be on top.
2. Install either **M4x12 bolt (M-A)** or **M5x12 bolt (M-B)**, **Washer (M-C)** into the display's 2 upper mounting holes only. Do not fully tighten the bolts, leave approximately 3mm space for easy mounting onto the VESA plate.
3. Mount the display onto the VESA plate, insert bolts into the remaining mounting holes, then fully tighten all 4 bolts using a Phillips screwdriver to secure the display.

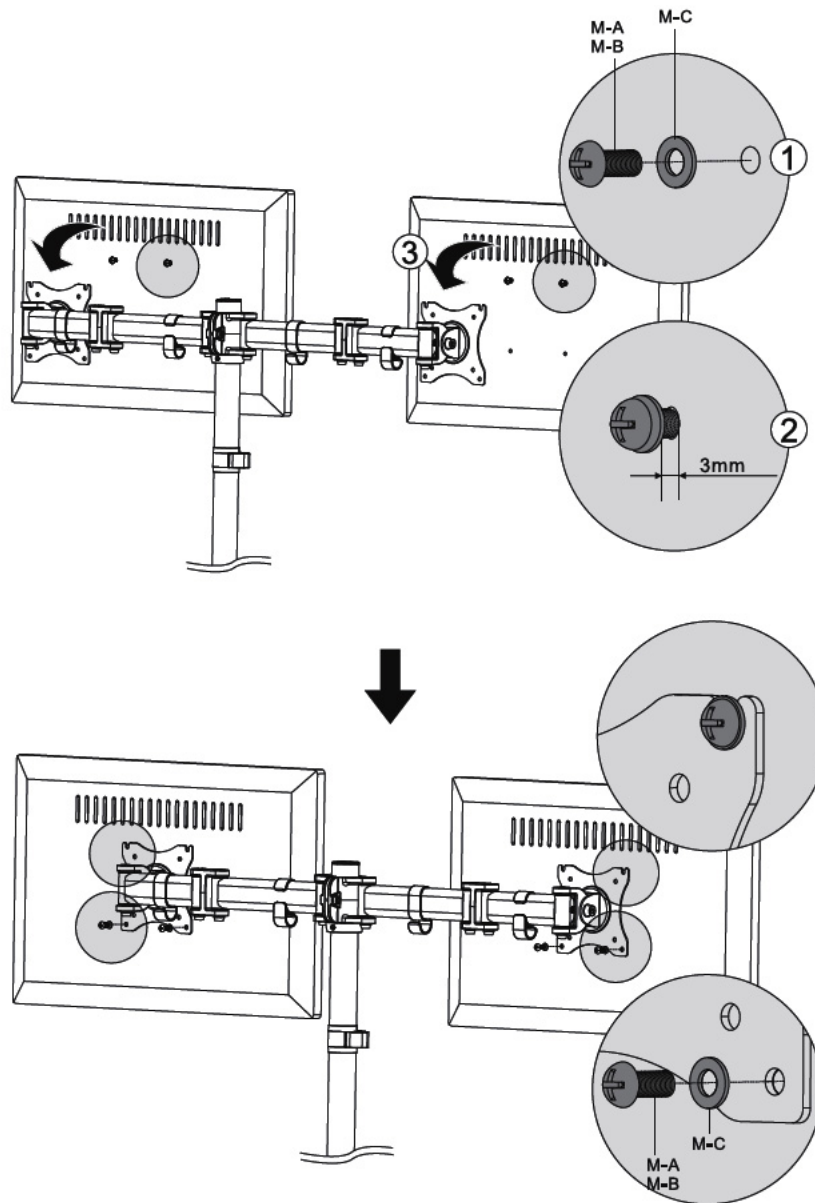

Figure 3

Step 4 - Tilt Angle Adjustment

- 1. Use Allen Key (H) to loosen the Tightening Bolt, then tighten the bolt to fix the tilt angle as shown in Figure 4.

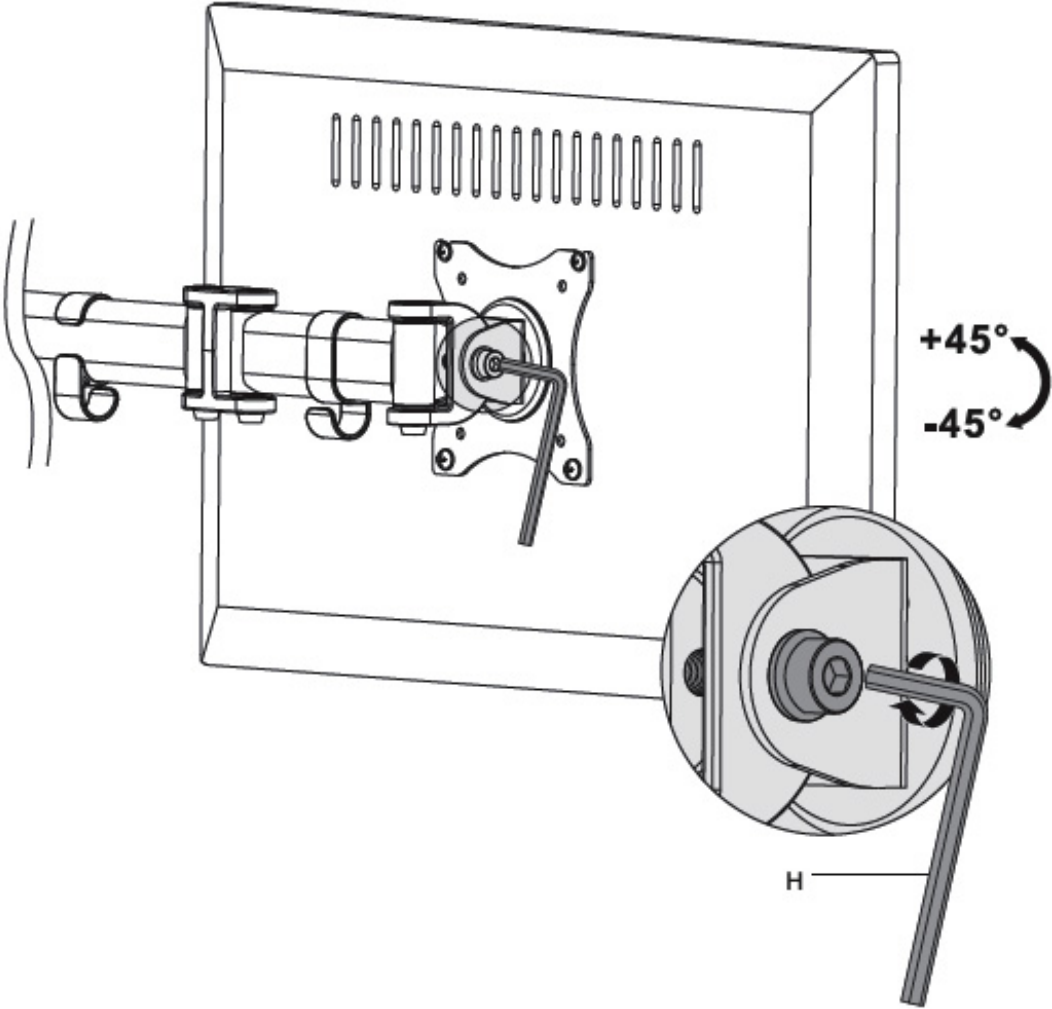

Figure 4

Step 5 - Final Adjustment and Cable Management

Adjusting the Position of the Displays

Position the displays so that they are centered over the weighted base. Placing the displays either forward or behind the center may cause the desk stand to tip over. See **Figure 5a**.

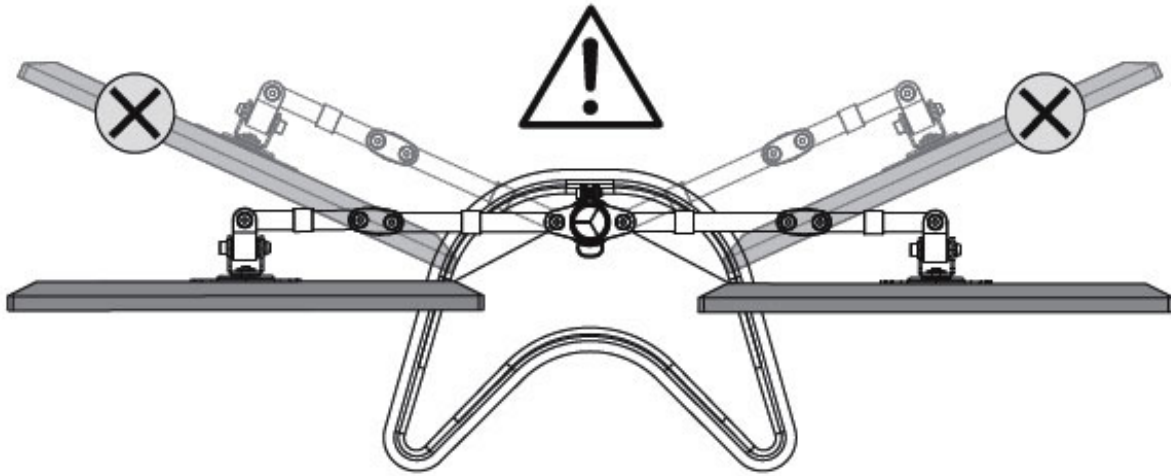

Figure 5a

Cable Management and Rotation

Route the cables through the wire clips and down the tube support. Rotate the displays to the desired position. See **Figure 5b**.

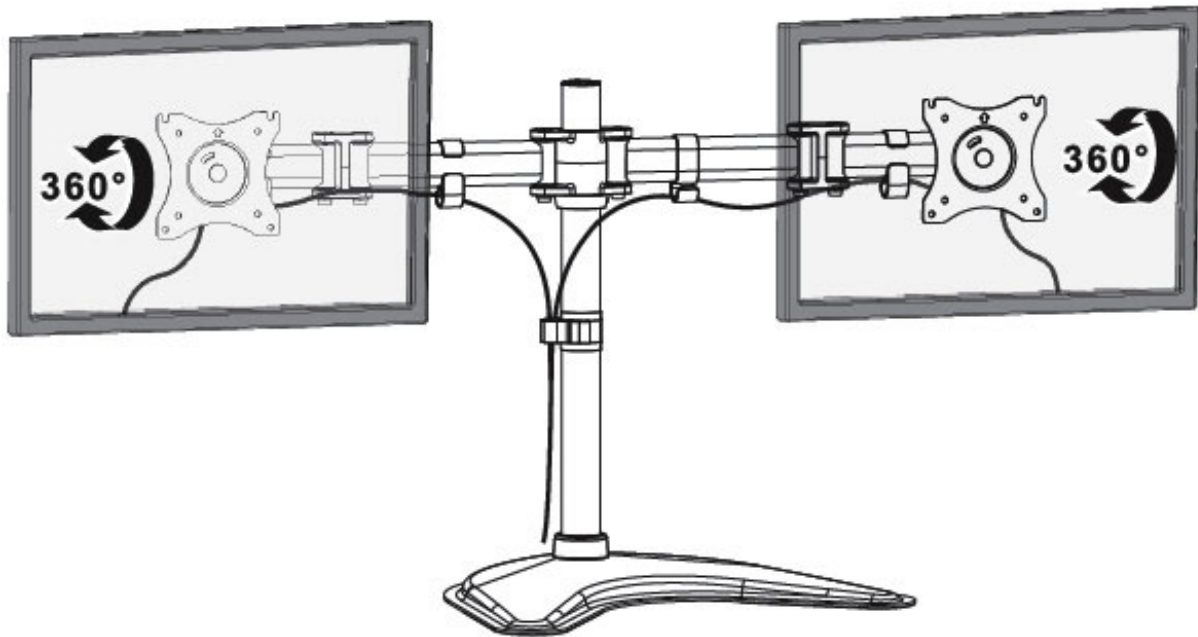

Figure 5b

Storage

Store the Allen Keys into the Cable Management clip as shown in **Figure 5c**.

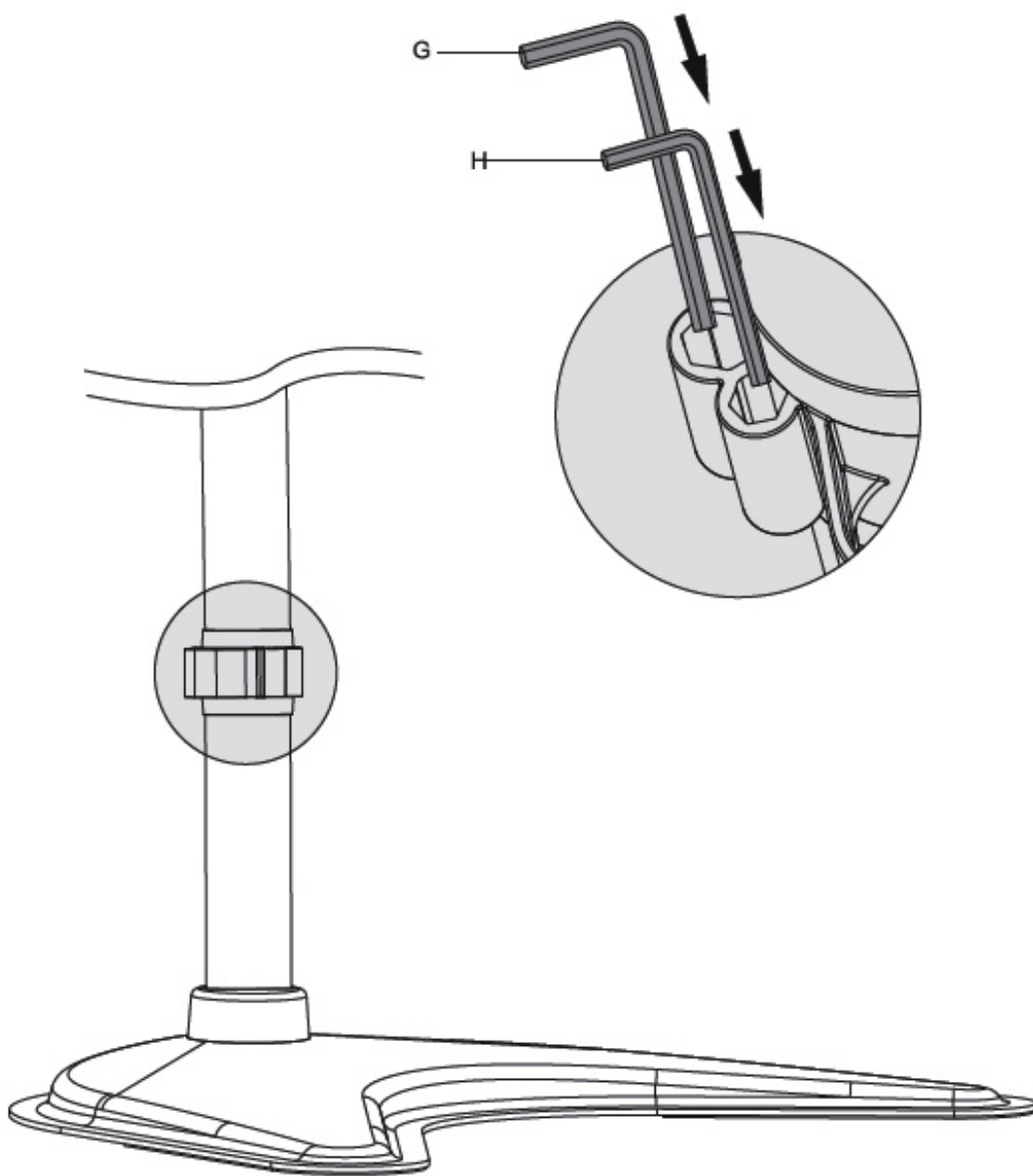

Figure 5c

Maintenance

Check the mounting screws every two months for tightness.

Blank Page

Technical Support and Warranty

QUESTIONS? SIIG's **Online Support** has answers! Simply visit our web site at www.siig.com and click **Support**. Our online support database is updated daily with new drivers and solutions. Answers to your questions could be just a few clicks away. You can also submit questions online and a technical support analyst will promptly respond.

SIIG offers a 5-year manufacturer warranty with this product. This warranty covers the original purchaser and guarantees the product to be free of any defects in materials or workmanship for five (5) years from the date of purchase of the product.

SIIG will, at our discretion, repair or replace (with an identical product or product having similar features and functionality) the product if defective in materials or workmanship. This warranty gives you specific legal rights, and you may also have other rights which vary from state to state. Please see our web site for more warranty details.

If you encounter any problems with this product, please follow the procedures below.

A) If it is within the store's return policy period, please return the product to the store where you purchased from.

B) If your purchase has passed the store's return policy period, please follow the steps below to have the product repaired or replaced.

Step 1: Submit your RMA request.

Go to www.siig.com, click **Support**, then **Request A Product Replacement** to submit a request to [SIIG RMA](#) or fax a request to 510-657-5962. Your RMA request will be processed, if the product is determined to be defective, an RMA number will be issued.

Step 2: After obtaining an RMA number, ship the product.

- Properly pack the product for shipping. All accessories that came with the original package must be included.
- Clearly write your RMA number on the top of the returned package. SIIG will refuse to accept any shipping package, and will not be responsible for a product returned without an RMA number posted on the outside of the shipping carton.
- You are responsible for the cost of shipping to SIIG. Ship the product to the following address:
SIIG, Inc.
6078 Stewart Avenue
Fremont, CA 94538-3152, USA
RMA #: _____
- SIIG will ship the repaired or replaced product via Ground in the U.S. and International Economy outside of the U.S. at no cost to the customer.

About SIIG, Inc.

Founded in 1985, SIIG, Inc. is a leading manufacturer of IT connectivity solutions (including Serial ATA and Ultra ATA Controllers, FireWire, USB, and legacy I/O adapters) that bridge the connection between Desktop/Notebook systems and external peripherals. SIIG continues to grow by adding A/V and Digital Signage connectivity solutions to our extensive portfolio. All centered around the distribution and switching of A/V signals over CAT5/6, these products include matrix switches, distribution amplifiers, extenders, converters, splitters, cabling, and more.

SIIG is the premier one-stop source of upgrades and is committed to providing high quality products while keeping economical and competitive prices. High-quality control standards are evident by one of the lowest defective return rates in the industry. Our products offer comprehensive user manuals, user-friendly features, and most products are backed by a lifetime warranty.

SIIG products can be found in many computer retail stores, mail order catalogs, and e-commerce sites in the Americas, as well as through major distributors, system integrators, and VARs.

<p>PRODUCT NAME</p>

<p>Articulated Freestanding Dual Monitor Desk Stand 13" to 27"</p>
--

Articulated Freestanding Dual Monitor Desk Stand - 13" to 27" is a trademark of SIIG, Inc. SIIG and the SIIG logo are registered trademarks of SIIG, Inc. All other names used in this publication are for identification only and may be trademarks of their respective owners.