

Fixed LCD TV/Monitor Mount 10" to 24" Installation Instructions



IMPORTANT: If you don't understand the installation instructions, please consult an installation specialist.

Caution

- This mount contains small parts which can act as a choking hazard if swallowed.
- **CAUTION:** The maximum load capacity is 33lbs (15kg). Use with products exceeding the maximum load capacity may cause serious injury. See apparatus instructions.
- The wall structure must be capable of supporting at least five (5) times the maximum load capacity as indicated. If not, the wall must be reinforced.

Hardware Kit

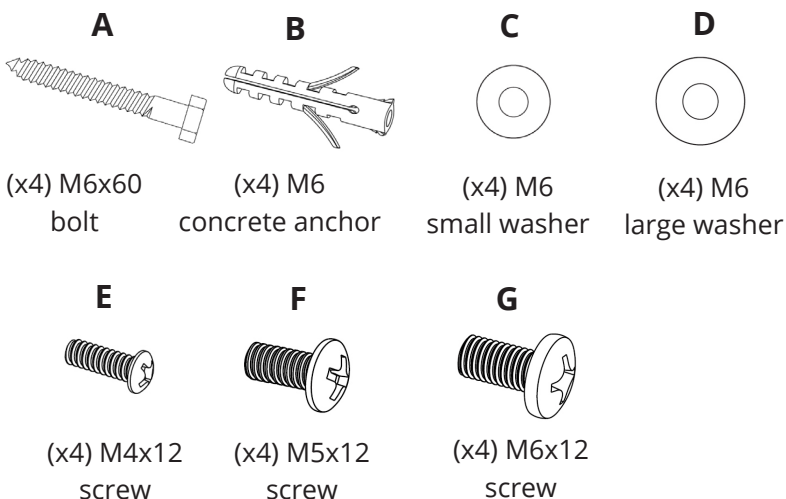

Tools Required: Electronic stud finder, #2 Phillips head screw driver, drill, 1/8" drill bit (wood stud installation), 3/8" masonry drill bit (concrete/brick wall installation).

Step 1: Wall Plate Installation

Wood Stud Installation

1. Use a high quality electronic stud finder (commercially available) to locate dead center of a wood stud and mark the location with an awl or pencil (Figure 1).
2. Hold the wall plate to the wall, use the two center mounting holes to mark the locations to be used for mounting the wall plate.
3. Take down the wall plate and drill two 2" deep holes, using a 1/8" drill bit, at the positions you've marked.
4. Position the wall plate to the wall again and insert bolts (A) and washers (D) into the holes and tighten (Figure 2). **Note:** When mounting the wall plate, make sure the top of the mounting rails are pointed in.

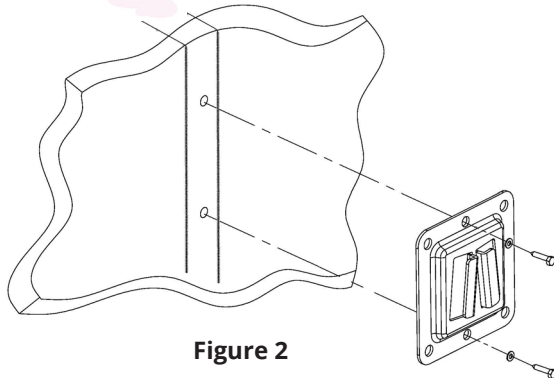
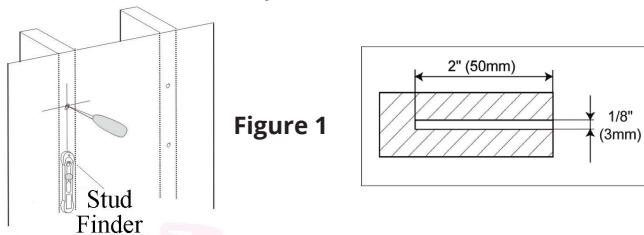

Concrete/Brick Wall Installation

1. Hold the wall plate (Figure 3) to the wall, use the four corner mounting holes to mark the locations to be used for mounting the wall plate. Locate the holes directly into the brick, block or concrete, never into the mortar between the blocks.
2. Pre-drill four holes to a depth of 2" using a 3/8" masonry drill bit at the positions you've marked and insert one concrete anchor (B) into each hole.
3. Position the wall plate to the wall again and insert the bolts (A) and washers (D) into the anchor as shown (Figure 4). **Note:** When mounting the wall plate, make sure the top of the mounting rails are pointed in.

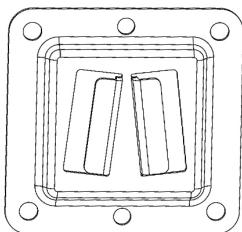

Figure 3

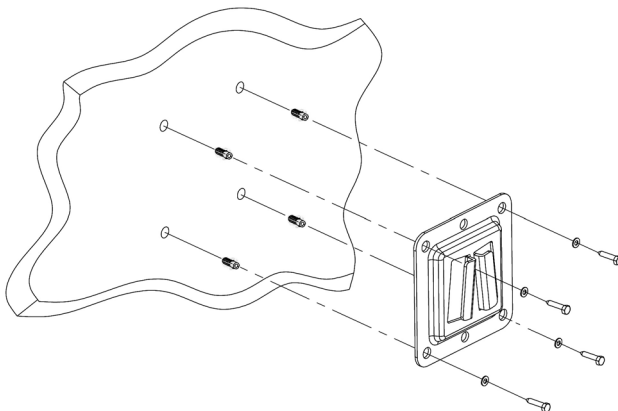
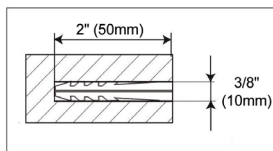

Figure 4

Step 2: Display Plate Installation

1. Place your TV screen down on a soft, flat surface, and locate the threaded mounting points that are located on the back of the display.
2. According to the size of the display's hole, choose the corresponding screw (E/F/G) and washer (C) and insert into the hole as shown (Figure 5) and tighten. **Note:** When mounting the display plate, make sure the top of the mounting rails are pointed in.

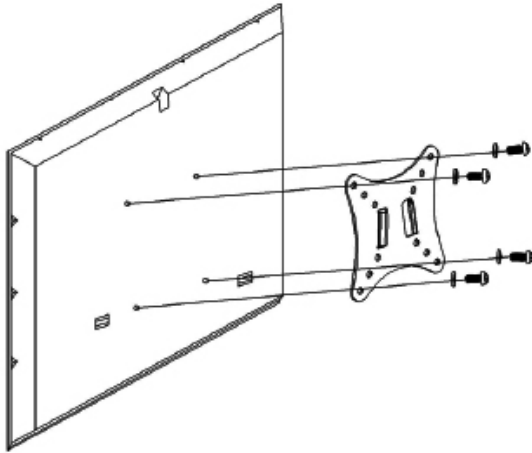

Figure 5

Step 3: Final Installation

1. Hang the display plate onto the top of the wall plate and slip it into the wall plate as shown (Figure 6).

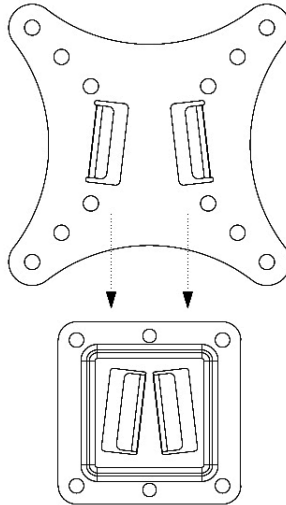

Figure 6

Maintenance

Check the mounting screws every two months for tightness.

Technical Support and Warranty

QUESTIONS? SIIG's **Online Support** has answers! Simply visit our web site at www.siig.com and click **Support**. Our online support database is updated daily with new drivers and solutions. Answers to your questions could be just a few clicks away. You can also submit questions online and a technical support analysts will promptly respond.

SIIG offers a 5-year manufacturer warranty with this product. This warranty covers the original purchaser and guarantees the product to be free of any defects in materials or workmanship for five (5) years from the date of purchase of the product.

SIIG will, at our discretion, repair or replace (with an identical product or product having similar features and functionality) the product if defective in materials or workmanship. This warranty gives you specific legal rights, and you may also have other rights which vary from state to state. Please see our web site for more warranty details.

If you encounter any problems with this product, please follow the procedures below.

A) If it is within the store's return policy period, please return the product to the store where you purchased it.

B) If your purchase has passed the store's return policy period, please follow these steps to have the product repaired or replaced.

Step 1: Submit your RMA request. Go to www.siig.com, click **Support**, then **Request A Product Replacement** to submit a request to [SIIG RMA](#) or fax a request to 510-657-5962. Your RMA request will be processed, if the product is determined to be defective, an RMA number will be issued.

Step 2: After obtaining an RMA number, ship the product.

- Properly pack the product for shipping. All software, cable(s) and any other accessories that came with the original package must be included.
- Clearly write your RMA number on the top of the returned package. SIIG will refuse to accept any shipping package, and will not be responsible for a product returned without an RMA number posted on the outside of the shipping carton.
- You are responsible for the cost of shipping to SIIG. Ship the product to the following address:

SIIG, Inc.

6078 Stewart Avenue

Fremont, CA 94538-3152, USA

RMA #: _____

- SIIG will ship the repaired or replaced product via Ground in the U.S. and International Economy outside of the U.S. at no cost to the customer.

About SIIG, Inc.

Founded in 1985, SIIG, Inc. is a leading manufacturer of IT connectivity solutions (including Serial ATA and Ultra ATA Controllers, FireWire, USB, and legacy I/O adapters) that bridge the connection between Desktop/Notebook systems and external peripherals. SIIG continues to grow by adding A/V and Digital Signage connectivity solutions to our extensive portfolio. All centered around the distribution and switching of A/V signals over CAT5/6, these products include matrix switches, distribution amplifiers, extenders, converters, splitters, cabling, and more. SIIG is the premier one-stop source of upgrades and is committed to providing high quality products while keeping economical and competitive prices. High-quality control standards are evident by one of the lowest defective return rates in the industry. Our products offer comprehensive user manuals, user-friendly features, and most products are backed by a lifetime warranty.

SIIG products can be found in many computer retail stores, mail order catalogs, and e-commerce sites in the Americas, as well as through major distributors, system integrators, and VARs.

PRODUCT NAME

Fixed LCD TV/Monitor Mount - 10" to 24"

FCC RULES: TESTED TO COMPLY WITH FCC PART 15, CLASS B
OPERATING ENVIRONMENT: FOR HOME OR OFFICE USE

FCC COMPLIANCE STATEMENT:

This device complies with part 15 of the FCC Rules. Operation is subject to the following two conditions: (1) This device may not cause harmful interference, and (2) this device must accept any interference received, including interference that may cause undesired operation.

THE PARTY RESPONSIBLE FOR PRODUCT COMPLIANCE

**SIIG, Inc.
6078 Stewart Avenue
Fremont, CA 94538-3152, USA
Phone: 510-657-8688**

Fixed LCD TV/Monitor Mount - 10" to 24" is a trademark of SIIG, Inc. SIIG and the SIIG logo are registered trademarks of SIIG, Inc. All other names used in this publication are for identification only and may be trademarks of their respective owners.