

Easy-Adjust Dual Monitor Desk Stand 13" to 27"

Installation Instructions

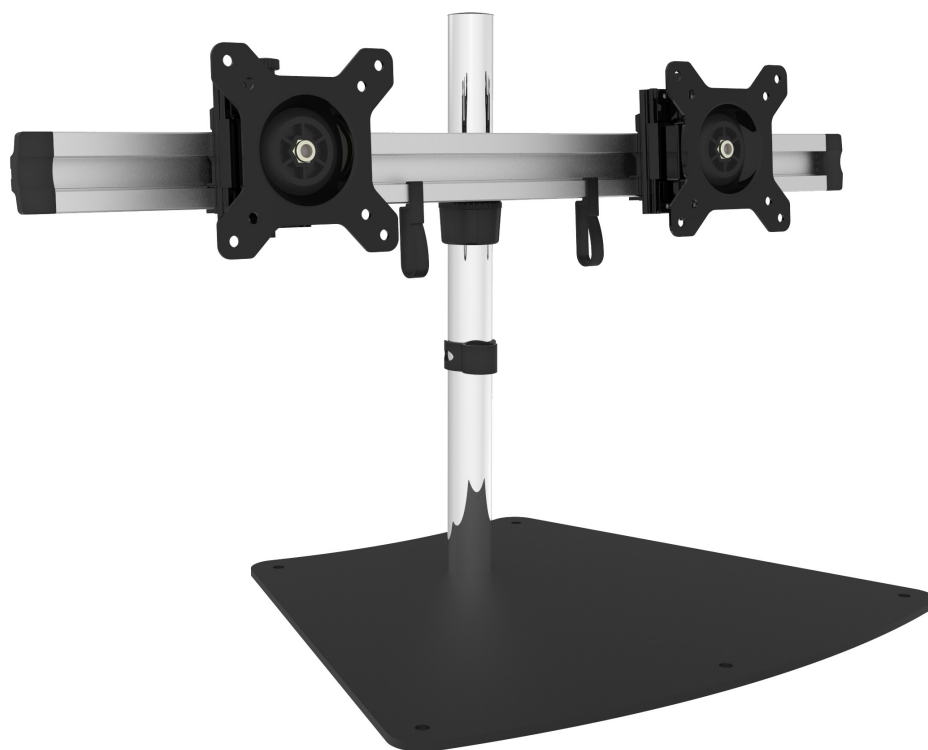

Unpacking

- Carefully remove the contents and lay them out on cardboard or other protective surface
- Check package contents against the parts list to ensure that all components were received and undamaged. Do not use damaged or defective parts
- Carefully read all instructions before attempting the installation

Safety Information

- Use proper safety equipment during installation
- If you don't understand the installation instructions, please consult an installation specialist
- This mount contains small parts which can act as a choking hazard if swallowed
- Do not use this product for any purpose or in any configuration not explicitly specified in these instructions

Tools Required

- Phillips screwdriver

Parts List



Weighted Base

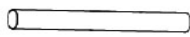

Tube Support

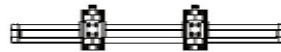

Arm Assembly



VESA Plate



Cable Management Clip



a1 - (1x) Plastic Cap



b1 - (1x) Position Ring



c1 - (3x) M6x16 Bolt



A - (8x) M4x12 Bolt



B - (8x) M4x30 Bolt



C - (8x) Spacer



D - (1x) 3mm Allen Key



E - (1x) 4mm Allen Key



F - (2x) Wire Clip



G - (1x) 5mm Allen Key

Installation

Step 1 - Mount the Tube Support to the Weighted Base

Mount the **Tube Support** to the **Weighted Base** using 3 **M6x16 Bolts (c1)**, tighten them using the **4mm Allen Key (E)**, see **Figure 1**.

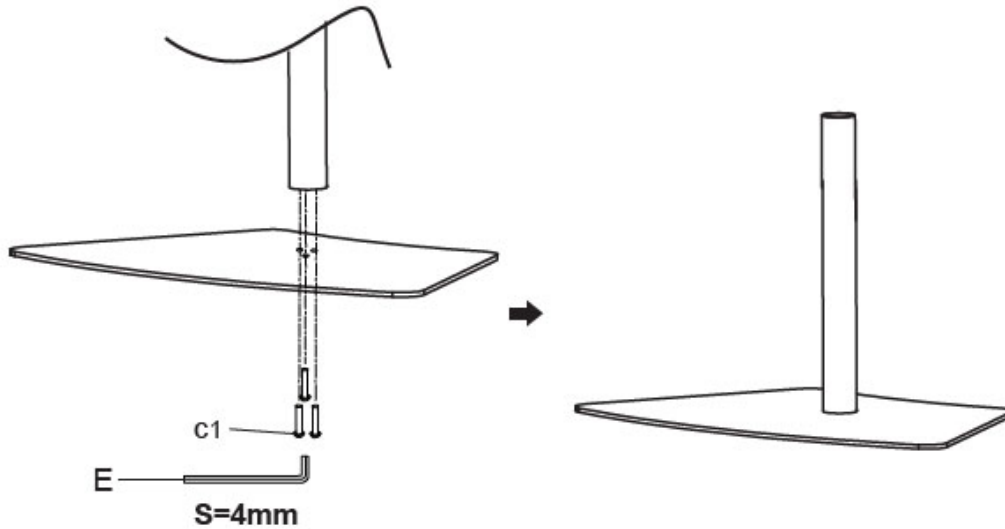

Figure 1

Step 2 - Install the Arm Assembly onto the Tube Support

1. Install the **Position Ring (b1)** at the desired height then tighten the screw to secure it. Next, slide the **Arm Assembly** onto the tube support so it rests on the Position Ring. Make sure the **Fine Tune Height Adjustment Knob** is facing up. Install the **Plastic Cap (a1)**, see **Figure 2A**.

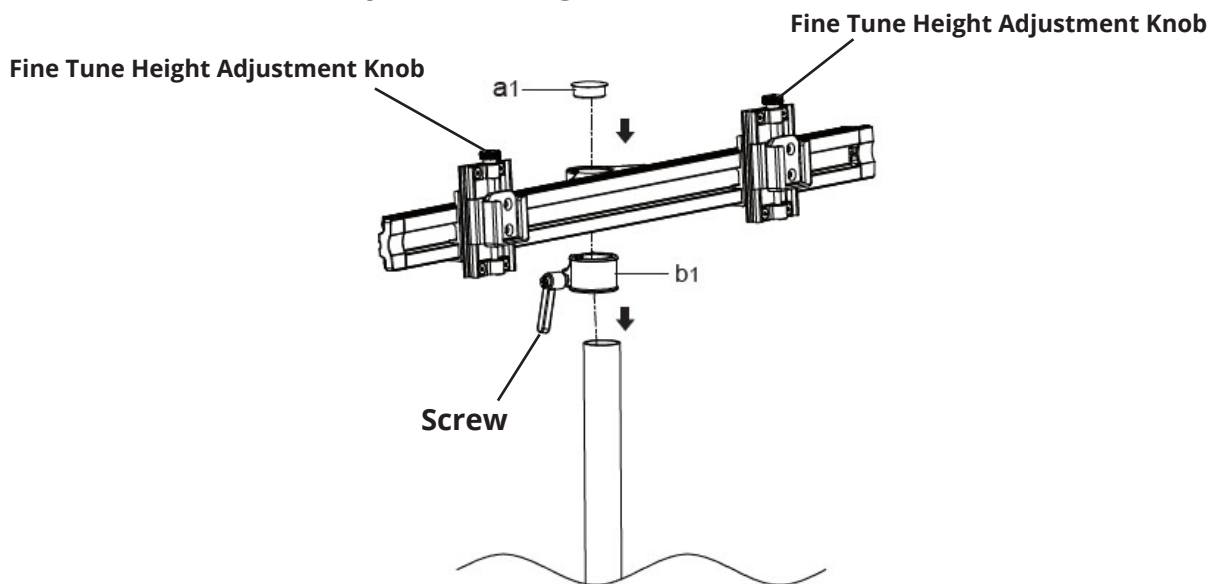

Figure 2A

- Secure the Arm Assembly by tightening the Hex Nuts finger tight using the included **3mm Allen Key (D)** as shown in **Figure 2B**. Install the **Cable Management Clip** onto the Tube Support, see **Figure 2B**.

Note: The Arm Assembly is intended to rotate and is not meant to be attached in a fixed position. Over tightening the Hex Nuts may result in damage to the Arm Assembly and Tube Support.

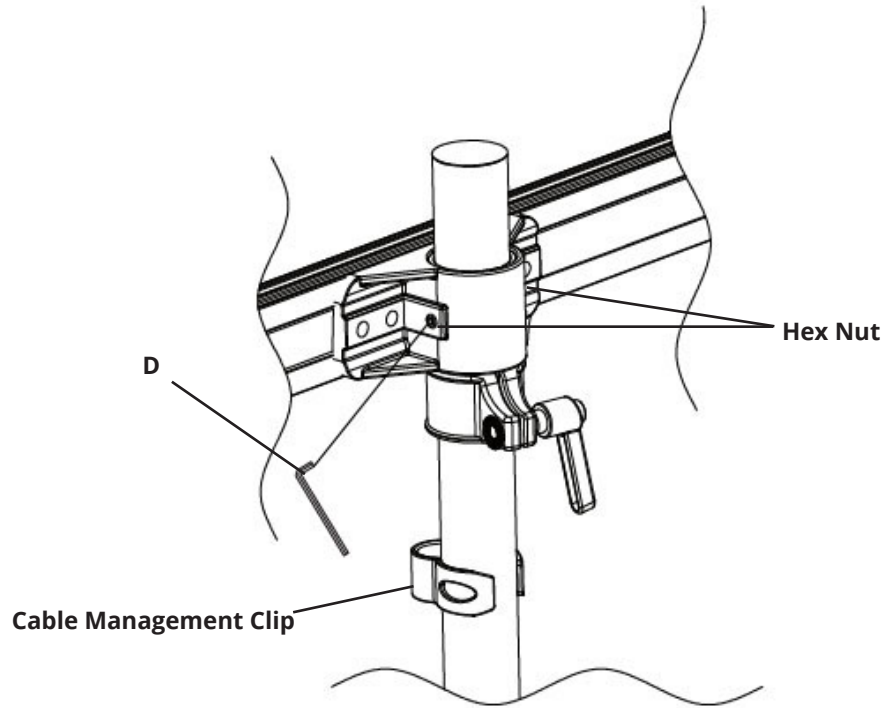

Figure 2B

Step 3 - Mounting the Displays to the VESA plate.

1. For flat back display surface install **M4x12 Bolt (A)** through the faceplate into the display's mounting holes, see **Figure 3A**.
2. For recessed or curved back display surface place **Spacer (C)** between the faceplate and display and install **M4x30 Bolt (B)** through the faceplate into the display's mounting holes, see **Figure 3B**.

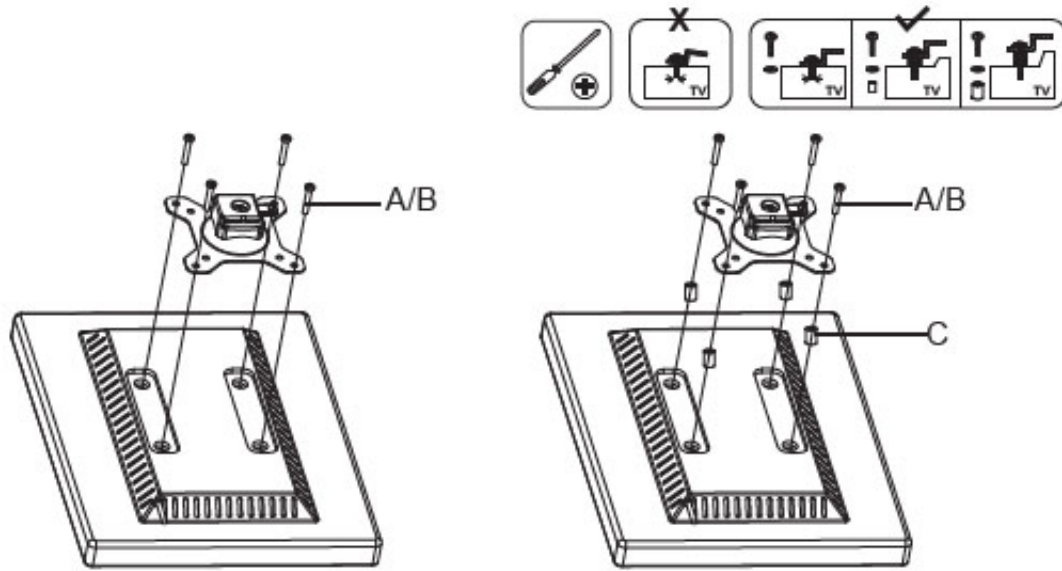

Figure 3A

Figure 3B

Step 4 - Mounting the Displays to the Arm Assembly

1. Slide the Vesa Plate onto the VESA plate holder, see **Figure 4A**.
2. Use a Phillips screwdriver to secure the VESA Plate to the holder, see **Figure 4B**.

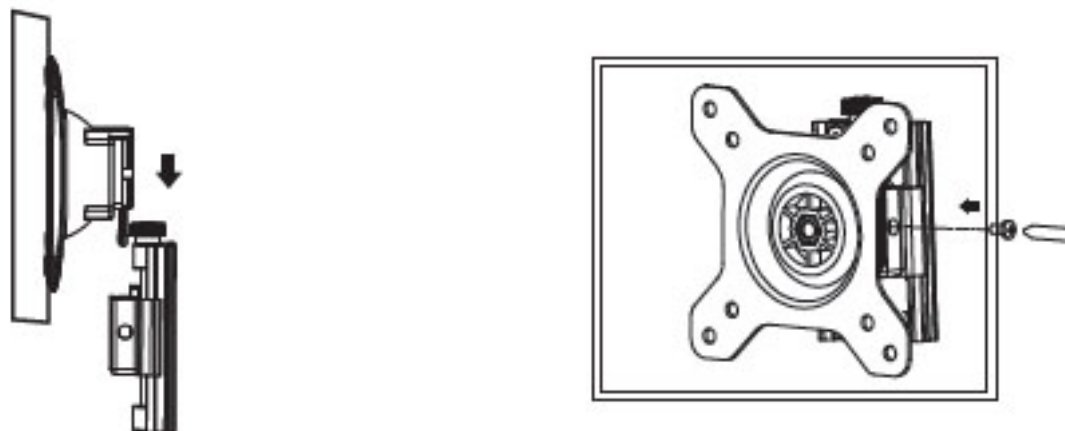

Figure 4A

Figure 4B

We suggest you have a helper hold the desk stand upright while attaching your displays to prevent damage to the displays or desk stand and to ensure your personal safety.

Step 5 - Arranging the Displays

1. Move the displays horizontally into the desired position and secure them using the locking knob at the bottom of the VESA plate holder, see **Figure 5**.

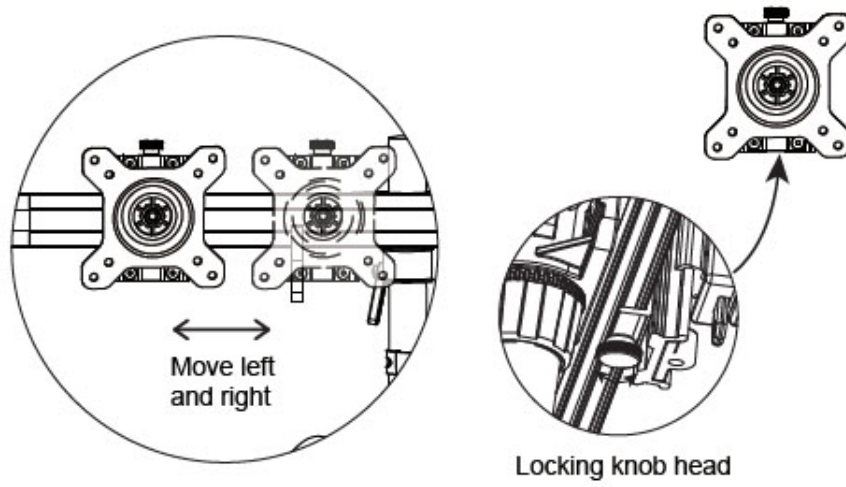

Figure 5

2. Move the displays vertically into the desired position using the **Fine Tune Height Adjustment Knob** at the top of the VESA plate holder and install the **Wire Clips (F)**, see **Figure 6**.

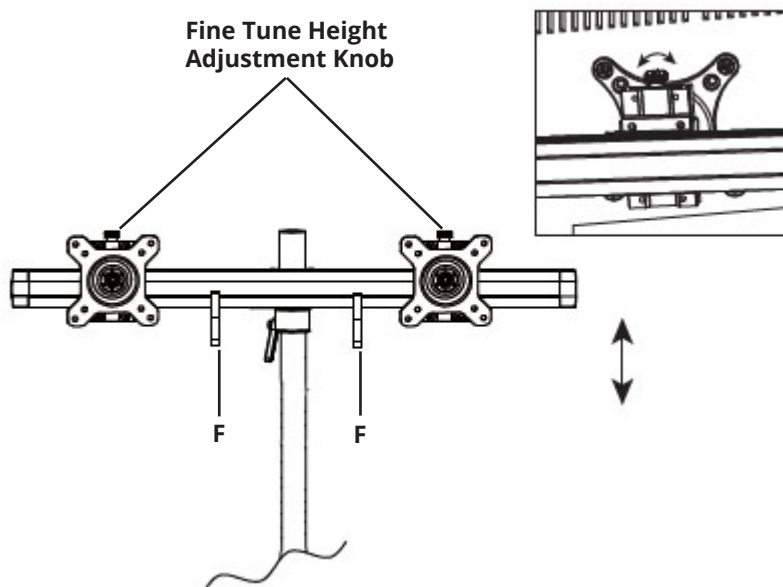

Figure 6

Step 6 - Final Adjustment and Cable Management

1. Route the cables through the wire clips and down the tube support, see **Figure 7**.

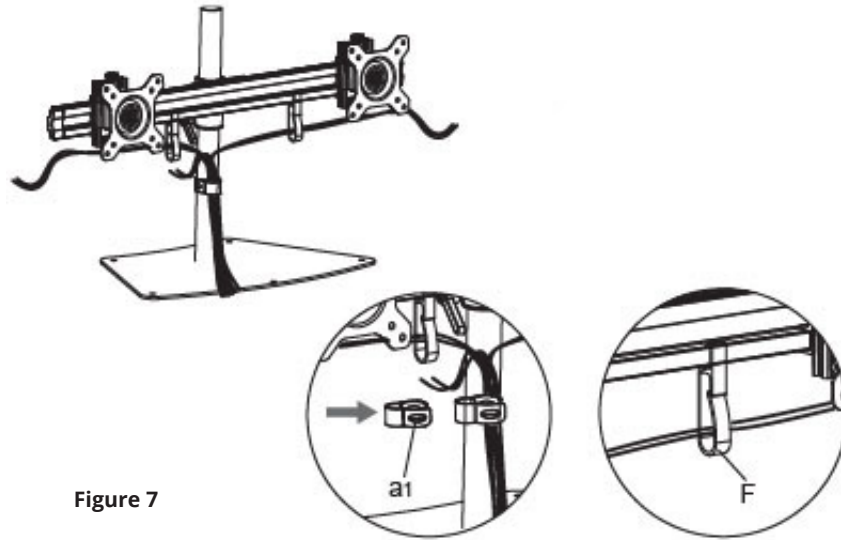

Figure 7

2. Adjust the display tilt angle to the desired position, see **Figure 8**.

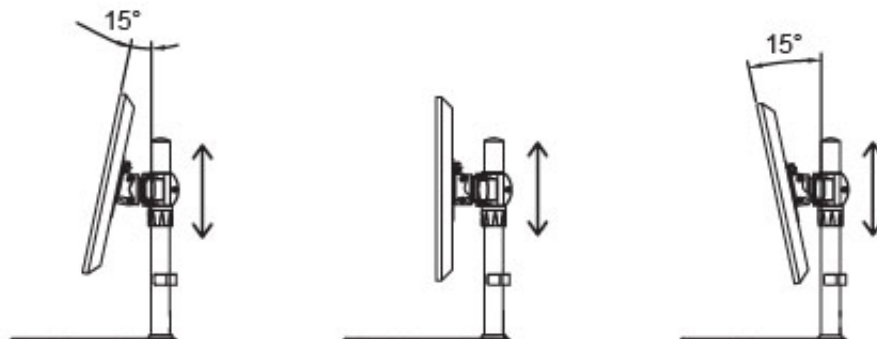
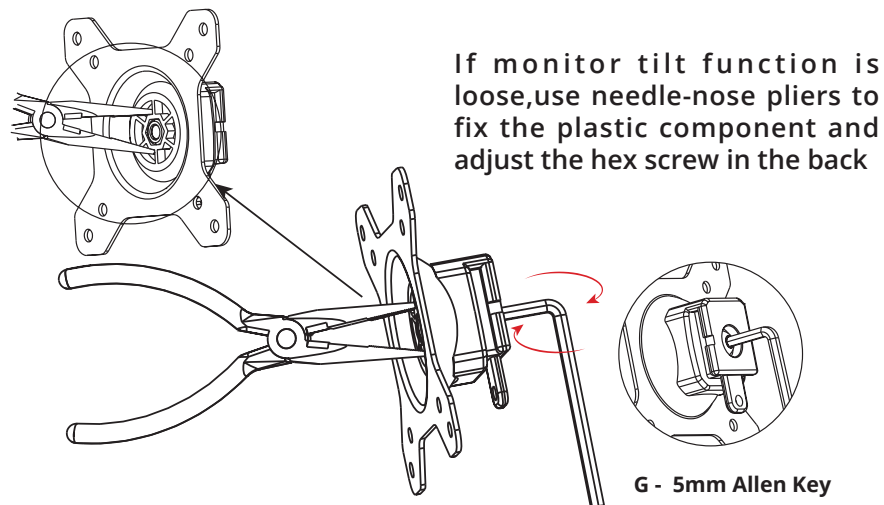

Figure 8



Maintenance

Check the mounting screws every two months for tightness.

Technical Support and Warranty

QUESTIONS? SIIG's **Online Support** has answers! Simply visit our web site at www.siig.com and click **Support**. Our online support database is updated daily with new drivers and solutions. Answers to your questions could be just a few clicks away. You can also submit questions online and a technical support analyst will promptly respond.

SIIG offers a 3-year manufacturer warranty with this product. This warranty covers the original purchaser and guarantees the product to be free of any defects in materials or workmanship for three (3) years from the date of purchase of the product.

SIIG will, at our discretion, repair or replace (with an identical product or product having similar features and functionality) the product if defective in materials or workmanship. This warranty gives you specific legal rights, and you may also have other rights which vary from state to state. Please see our web site for more warranty details.

If you encounter any problems with this product, please follow the procedures below.

A) If it is within the store's return policy period, please return the product to the store where you purchased from.

B) If your purchase has passed the store's return policy period, please follow the steps below to have the product repaired or replaced.

Step 1: Submit your RMA request.

Go to www.siig.com, click **Support**, then **Request A Product Replacement** to submit a request to [SIIG RMA](#) or fax a request to 510-657-5962. Your RMA request will be processed, if the product is determined to be defective, an RMA number will be issued.

Step 2: After obtaining an RMA number, ship the product.

- Properly pack the product for shipping. All accessories that came with the original package must be included.
- Clearly write your RMA number on the top of the returned package. SIIG will refuse to accept any shipping package, and will not be responsible for a product returned without an RMA number posted on the outside of the shipping carton.
- You are responsible for the cost of shipping to SIIG. Ship the product to the following address:

SIIG, Inc.

6078 Stewart Avenue

Fremont, CA 94538-3152, USA

RMA #: _____

- SIIG will ship the repaired or replaced product via Ground in the U.S. and International Economy outside of the U.S. at no cost to the customer.

About SIIG, Inc.

Founded in 1985, SIIG, Inc. is a leading manufacturer of IT connectivity solutions (including Serial ATA and Ultra ATA Controllers, FireWire, USB, and legacy I/O adapters) that bridge the connection between Desktop/Notebook systems and external peripherals. SIIG continues to grow by adding A/V and Digital Signage connectivity solutions to our extensive portfolio. All centered around the distribution and switching of A/V signals over CAT5/6, these products include matrix switches, distribution amplifiers, extenders, converters, splitters, cabling, and more.

SIIG is the premier one-stop source of upgrades and is committed to providing high quality products while keeping economical and competitive prices. High-quality control standards are evident by one of the lowest defective return rates in the industry. Our products offer comprehensive user manuals, user-friendly features, and most products are backed by a lifetime warranty.

SIIG products can be found in many computer retail stores, mail order catalogs, and e-commerce sites in the Americas, as well as through major distributors, system integrators, and VARs.

<p>PRODUCT NAME</p>

<p>Easy-Adjust Dual Monitor Desk Stand 13" to 27"</p>

Easy-Adjust Dual Monitor Desk Stand - 13" to 27" is a trademark of SIIG, Inc. SIIG and the SIIG logo are registered trademarks of SIIG, Inc. All other names used in this publication are for identification only and may be trademarks of their respective owners.