



HD/SD-SDI over Single mode SFP-type Fiber Optic Extender Immune to Pathological





Safety and Notice

The **AV-GM02G3-S1 3G/HD/SD-SDI over Single mode SFP-type Fiber Optic Extender Immune to Pathological** has been tested for conformance to safety regulations and requirements, and has been certified for international use. However, like all electronic equipments, the **AV-GM02G3-S1** should be used with care. Please read and follow the safety instructions to protect yourself from possible injury and to minimize the risk of damage to the unit.

- Follow all instructions and warnings marked on this unit.
- Do not attempt to service this unit yourself, except where explained in this manual.
- Provide proper ventilation and air circulation and do not use near water.
- Keep away the objects that might damage the device and assure that the placement of this unit is on a stable surface.
- Use only the power adapter, power cords and connection cables designed for this unit.
- Do not use liquid or aerosol cleaners to clean this unit. Always unplug the power to the device before cleaning.

The AV-GM02G3-S1 is an ideal and economic solution designed for transmission of multi-rate SDI video, with embedded audio and metadata over a single-mode fiber optic cable. The transmitter module receives one 3G/HD/SDI electrical input, perfectly converts SMPTE 292M, SMPTE 259M, SMPTE 424M or DVB-ASI electrical SDI signal to single-mode optical SDI signals. The receiver module receives optical signal from input SFP connector, and then perfectly converts it to electrical SDI signal. AV-GM02G3-S1 is immune to pathological pattern (SMPTE RP-198) without introducing any flickers, and this feature further guarantees the transmission quality over optical fibers.

Both transmitter and receiver provide equalizing and reclocking at input unit in order to re-construct the signal for consistent quality. The AV-GM02G3-S1 is perfect for today's broadcast applications, including video production, video editing, studio to studio and studio to CATV head end. In addition, since transmission of content is inherently secure and immune to outside interference, fiber applications are favored in government, military, and medical environments.

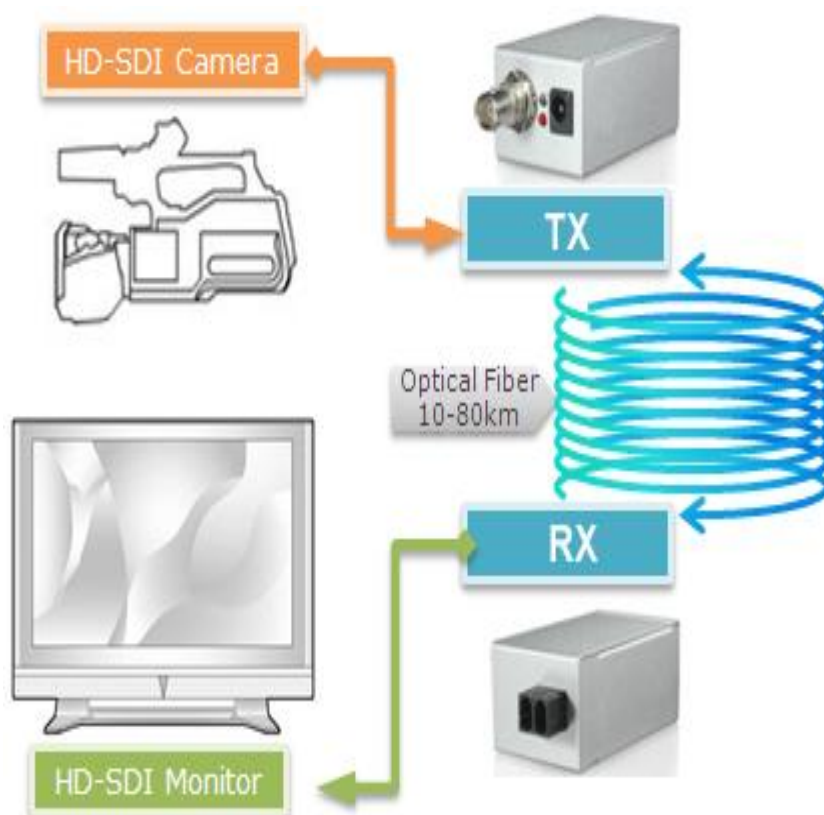

Features

- Enable transmission of digital video signal over optical fiber*
 - up to 10 km (6.25 miles) [AV-GM02G3-S110]
 - up to 20 km (12.5 miles) [AV-GM02G3-S120]
 - up to 80 km (50 miles) [AV-GM02G3-S180]
- Automatic cable EQ up to 300m (1000ft) at SD-SDI ,150m (500ft) for HD-SDI or 90m (295ft) for 3G HD-SDI
- Standard SFP-type fiber optic connector
- Supports following protocols:
 - SMPTE 259M (270Mbps)
 - SMPTE 259M (360Mbps)
 - SMPTE 292M / HDTV (1.485Gbps and 1.485/1.001Gbps)
 - SMPTE 424M / HDTV (2.97Gbps and 2.97/1.001Gbps)
 - DVB ASI (270Mbps)
- Immune to RP-918 pathological patterns
- Automatic reclocked / Manual bypass (optional upon request)
- One SDI loop out (optional upon request)
- 3G/HD/SDI Input signal detection LED



Specifications & Package Contents

Model Name	AV-GM02G3-S1	
Technical	AV-GM02G3-S1-TX	AV-GM02G3-S1-RX
Role of usage	Transmitter [TX]	Receiver [RX]
SDI standards	SD-SDI & HD-SDI	
Auto HD/SD-SDI detection	Yes	
Supported protocols	SMPTE 259M (270Mbps / 360Mbps), DVB ASI (270Mbps) SMPTE 292M / HDTV (1.485Gbps and 1.485/1.001Gbps) SMPTE 424M / HDTV (2.97Gbps and 2.97/1.001Gbps)	
Video bandwidth	[2.97Gbps & 2.97/1.001Gbps]	
Data rates	270 / 1483 / 1485 /2967/2970Mbps	
Video support	[HD] 720p50/59.94/60, 1035i50/59.94/60, 1080i50/59.94/60, 1080p24/30,1080p60,1080p59.94 [SD] NTSC@59.94Hz, PAL@50Hz	
SDI signal type	SMPTE-424M,SMPTE-292M, SMPTE-259M, DVB-ASI	
Output impedance	75Ω	
Auto reclocker mode	Automatic detection: 270Mbps / 1.483Gbps / 1.485Gbps/2.97Gbps/2.967Gbps Automatic bypass: 177Mbps / 360Mbps / 540Mbps	
Fiber Transmission	10km (6.25mi) [AV-GM02G3-S110] / 20km (12.5mi) [AV-GM02G3-S120] / 80km (50mi) [AV-GM02G3-S180]	
Cable (Belden 1694A) equalization / transmission	[3G HD-SDI] up to 90m (297ft) [HD-SDI] up to 150m (500ft) [SD-SDI] up to 300m (1000ft)	[3G HD-SDI] greater than 60m (196ft) [HD-SDI] greater than 125m (410ft) [SD-SDI] up to 300m (1000ft)
Loop-out	1 reclocking SDI loop-out [optional upon request]	
Audio support	Yes	
RP-918 pathological	Immune	

patterns	
PCB Stack-up	4-layer board [impedance control — differential 100Ω; single 50Ω]
Input	1x BNC [SDI] 1x Optical SFP [SDI]
Output	1x Optical SFP [SDI] 1x BNC [SDI] (optional loop-out) 1x BNC [SDI] 1x BNC [SDI] (optional upon request)
BNC connector	75Ω inter-locked socket
Optical fiber connector	SFP-type
Fiber optics	Wavelength: 1310 nm [AV-GM02G3-S110] 1550nm [AV-GM02G3-S120 / AV-GM02G3-S180] Type: Single-mode Extinction ratio: typical 9.5 (minimum 5) Jitter < 0.2 UI Rise/fall: 135~800 pS Overshoot < 10% Receiver sensitivity: -18 dBm Optical power: [AV-GM02G3-S110]-3~-9 dBm [AV-GM02G3-S120] -2~-7 dBm [AV-GM02G3-S180] -1~4 dBm
Mechanical	
Housing	Metal case
Dimensions [L x W x H]	Model 110 x 40 x 30mm [4.3"x1.6"x1.2"]
	Package 330 x 200 x 95mm [1'1"x7.9"x3.7"]
	Carton 495 x 440 x 380mm [1'7.5"x1'5.3"x1'3"]
Weight	Model [TX / RX] - 135g [4.8oz]
	Package 1075g [2.4 lbs]
Fixedness	Inter-locked power supply
Power supply	5V 4A DC
Power consumption	10 Watts [max]
Operation temperature	0~40°C [32~104°F]
Storage temperature	-20~60°C [-4~140°F]
Relative humidity	20~90% RH [no condensation]
Package Contents	1x AV-GM02G3-S1 [TX & RX] 2x 5V power adapter 1x User Manual

Transmitter (AV-GM02G3-S1-TX)

Front Panel

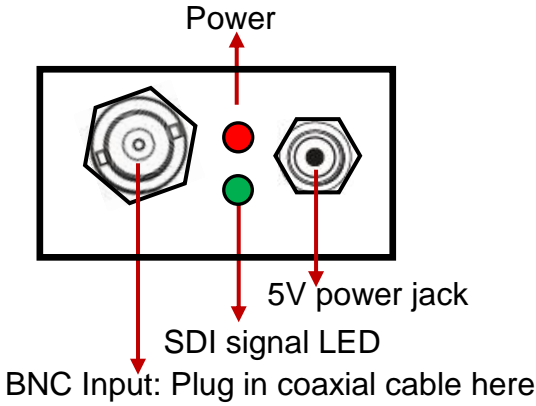

Rear Panel

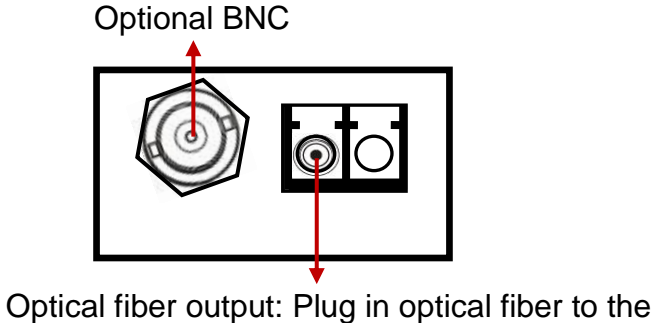

Receiver (AV-GM02G3-S1-RX)

Front Panel

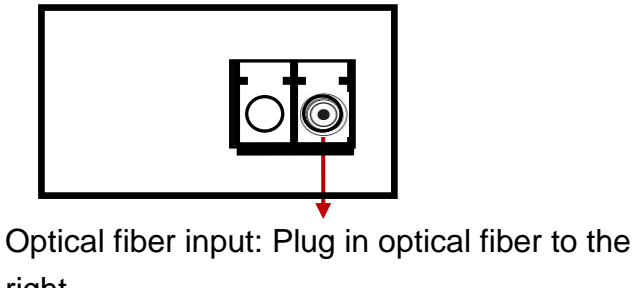

Rear Panel

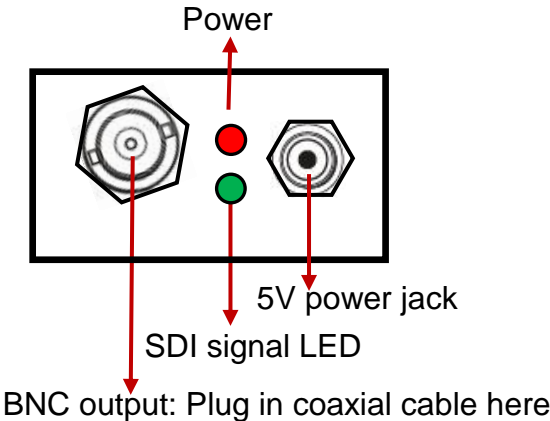

The SELLER warrants the **AV-GM02G3-S1 HD/SD-SDI over Singlemode SFP-type Fiber Optic Extender Immune to Pathological** to be free from defects in the material and workmanship for 3 years from the date of purchase from the SELLER or an authorized dealer. Should this product fail to be in good working order within 3 years warranty period, The SELLER, at its option, repair or replace the unit, provided that the unit has not been subjected to accident, disaster, abuse or any unauthorized modifications including static discharge and power surges.

Unit that fails under conditions other than those covered will be repaired at the current price of parts and labor in effect at the time of repair. Such repairs are warranted for 90 days from the day of reshipment to the BUYER. If the unit is delivered by mail, customers agree to insure the unit or assume the risk of loss or damage in transit. Under no circumstances will a unit be accepted without a return authorization number.

The warranty is in lieu of all other warranties expressed or implied, including without limitations, any other implied warranty or fitness or merchantability for any particular purpose, all of which are expressly disclaimed.

Proof of sale may be required in order to claim warranty. Customers outside Taiwan are responsible for shipping charges to and from the SELLER. Cables are limited to a 30 day warranty and cable must be free from any markings, scratches, and neatly coiled.

The content of this manual has been carefully checked and is believed to be accurate. However, The SELLER assumes no responsibility for any inaccuracies that may be contained in this manual. The SELLER will NOT be liable for direct, indirect, incidental, special, or consequential damages resulting from any defect or omission in this manual, even if advised of the possibility of such damages. Also, the technical information contained herein regarding the AV-GM02G3-S1 features and specifications is subject to change without further notice.

Support

For more info or tech support
<http://www.siig.com/support>