

Read the entire instruction manual before you start installation and assembly. If you have any question regarding any of the instructions or warnings, please contact us.

Unpacking

- Carefully remove the contents and lay them out on cardboard or other protective surface
- Check package contents against the parts list to ensure that all components are received undamaged. Do not use damaged or defective parts
- Ensure that you have received all parts according to the component checklist prior to installation. If any parts are missing or faulty, please contact us.

CAUTION:

Using the products heavier than the indicated weights as rated may result in instability and possible injury.

- Mount must be attached as specified in assembly instructions. Improper installation may result in damage or serious personal injury.
- Safety gear and proper tools must be used. This product should only be installed by professionals.
- This product is designed to be installed on wood stud walls, solid concrete walls or brick walls.
- Make sure that the supporting surface will safely support the combined weight of the equipment and all attached hardware and components.
- Use the mounting screws provided and DO NOT OVER TIGHTEN mounting screws
- This product contains small items that could be a choking hazard if swallowed. Keep these items away from children.
- This product is intended for indoor use only. Using this product outdoors could lead to product failure and personal injury.

MAINTENANCE

Check that the bracket is secure and safe to use at regular intervals (at least every three months)

Support

For more info or tech support <http://www.siig.com/support>



Ultra Heavy Duty Single Monitor Arm Desk Mount - 57"

Installation Guide

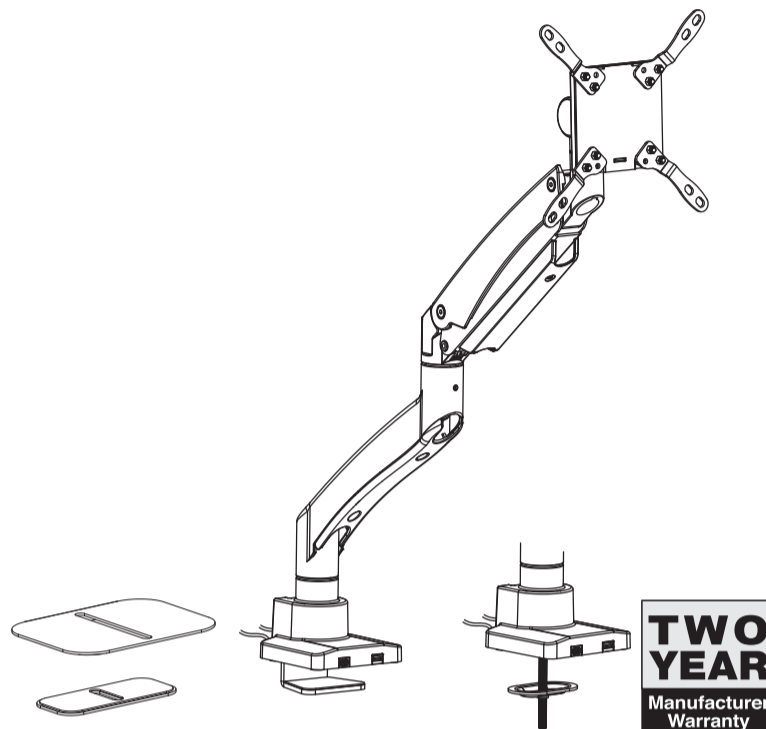

TWO YEAR
Manufacturer
Warranty

CE-MT3Z11-S1	VESA Compatible	57" MAX	2-27kg (4.4-59.5lbs) RATED
	75x75 100x100 200x100 200x200	FLAT/CURVED	

04-1421A

VESA 200x100 adapter setup

VESA 200x200 adapter setup

Note: Make sure the screws and VESA adapters are orientated correctly.

7 Latch VESA Plate and install both thumbscrews

CAUTION: DO NOT release the monitor immediately after hanging it onto the monitor arm. Wait until you are sure it is stable before releasing to prevent injury to personnel or equipment. If the arm rises or droops, refer to below steps for adjusting the gas spring tension.

8 **CAUTION:** To avoid damage to monitor or mount, always keep the arm in a horizontal position while making adjustments. Ask for assistance if required.

To properly balance the arm with monitor mounted, adjust the gas spring tension using the supplied Allen Key as follows:

- If the arm **droops**, turn the adjustment screw **counter-clockwise** until it stays in a horizontal position.
- If the arm **rises**, turn the adjustment screw **clockwise** until it stays in a horizontal position.

CAUTION: DO NOT over tighten the screws.

9 Removing cable covers

Installing cable covers

Installing tool holder

Note: If you prefer a counter-clockwise rotation, remove the screw on the back of the mounting plate and attach it to the other side as shown.

If the monitor does not stop at your desired **TILTING POSITION**, tighten the side screw as shown.

Counter-clockwise monitor rotation

Tilt monitor down

Clockwise monitor rotation

Tilt monitor up

You must face the Monitor towards the Front end and position it above the Desk at all times.

CAUTION: DO NOT position the Monitor past the Back end of the Desk. Doing so will result in the entire mount toppling.

